



October 14, 2024

Mr. Bills,

IHC Construction Companies, LLC, agrees to extend the current T&M contract to a 3.45% rate increase as allowed in the current contract.

Sincerely,

A handwritten signature in blue ink, appearing to read "L. Creadon", is written over a light blue horizontal line.

Lawrence C. Creadon
Director of Utility Operations

IV
BID FORM (Pricing)

The undersigned bidder agrees to all terms and conditions of the preceding specifications for 2025 Water Service Line Replacement Program and will furnish all the insurance documents and security deposits as stipulated. The unit prices listed below should be for 2025 only. Bid bond amount should be 10% of the sum of Bidder's Estimate amount listed below.

VILLAGE OF OAK PARK 2024 WATER SERVICE LINE REPLACEMENT PROGRAM PROJECT # 24-					
ITEM #	ITEM DESCRIPTION	QUANTITY	UNITS	UNIT PRICE	COST
1	TRENCH BACKFILL	750	CU.YD.	113.80	85,350.00
2	PROJECT MANAGEMENT(PUBLIC SIDE)	40	HR5	117.93	4,717.20
3	UTILITY LOCATION - PRIVATE PROPERTY	20	EACH	314.69	6,293.80
4	UTILITY CONFLICT POTHOLE	5	EACH	1,248.64	6,243.20
5	SERVICE CONNECTION TO WATER MAIN EXCAVATION	50	EACH	2,803.50	140,175.00
6	PARKWAY EXCAVATION	20	EACH	1,931.41	38,628.20
7	WATER SERVICE DISCONNECTION EXCAVATION	5	EACH	2,916.67	14,583.35
8	WATER SERVICE CONNECTION-PRIVATE PROPERTY	20	EACH	1,944.86	38,897.20
9	WATER SERVICE LINE, OPEN CUT, 1"	30	LIN.FT	181.04	5,431.20
10	WATER SERVICE LINE, OPEN CUT, 1-1/2"	30	LIN.FT	207.93	6,237.90
11	WATER SERVICE LINE, OPEN CUT, 2"	30	LIN.FT	212.07	6,362.10
12	WATER SERVICE LINE, DIRECTIONAL DRILL, 1"	2125	LIN.FT	44.40	94,350.00
13	WATER SERVICE LINE, DIRECTIONAL DRILL, 1-1/2"	450	LIN.FT	56.30	25,335.00
14	WATER SERVICE LINE, DIRECTIONAL DRILL, 2"	30	LIN.FT	142.76	4,282.80
15	WATER METER RELOCATION	2	EACH	724.15	1,448.30
16	WATER SERVICE LINE TYPE L 3/4"	40	LIN.FT	24.83	993.20
17	WATER SERVICE LINE TYPE L 1"	40	LIN.FT	30.00	1,200.00
18	REMOVE AND REPLACE HOT WATER HEATER	1	EACH	736.56	736.56
19	HAND DIG EXCAVATION ALLOWANCE, 5' DEEP	1	EACH	3,409.71	3,409.71
20	HAND DIG EXCAVATION ALLOWANCE, 6' DEEP	1	EACH	4,219.73	4,219.73
21	REMOVE AND REPLACE DRAIN TILES	5	LIN.FT	237.94	1,189.70
22	REMOVE AND REPLACE SEWER SERVICE LINES	25	LIN.FT	212.07	5,301.75
23	LANDSCAPE RESTORATION(PRIVATE PROPERTY)	100	SQ.FT	7.51	751.00
24	REMOVAL AND DISPOSAL OF CONTAMINATED MATERIAL	7	CU.YD.	335.18	2,346.26
				BIDDER'S ESTIMATE:	\$498,483.16

David J. Rock, President

(Print Name of Individual Signing)

Illinois Plumbing License #: 055-028260

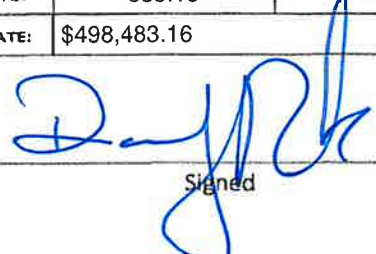
Signed

being first duly sworn on oath deposes and says that the bidder on the above Bid is organized as indicated below and that all statements herein made on behalf of such bidder and that their deponent is authorized to make them, and also deposes and says that deponent has examined and carefully prepared their Bid from the Agreement Specifications and has checked the same in detail before submitting this Bid; that the statements contained herein are true and correct.

Signature of bidder authorizes the Village of Oak Park to verify references of business and credit at its option.

Signature of bidder shall also be acknowledged before a Notary Public or other person authorized by law to execute such acknowledgments.

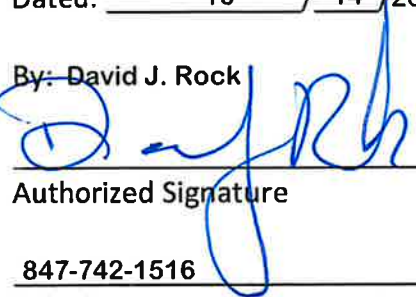
Dated: <u>10</u> / <u>14</u> / 2024	<u>IHC Construction Companies, LLC</u> Organization Name (Seal - If Corporation)
By: <u>David J. Rock</u> 	<u>385 Airport Rd., Suite 100 Elgin, IL 60123</u> Address
<u>847-742-1516</u> Telephone	<u>drock@ihcconstruction.com</u> E-mail

Subscribed and sworn to before me this 14th day of OCTOBER, 2024.

Naomi G. Murdoch in the State of IL, KANE COUNTY. My Commission
Notary Public

Expires on 08/29/2027



V
BIDDER CERTIFICATION

IHC Construction Companies, LLC, as part of its Bid on an agreement for 2025 Water service Line Replacement Program for the Village of Oak Park, hereby certifies that said bidder selected is not barred from proposing on the aforementioned agreement as a result of a violation to either Section 33E-3 or 33E-4 of Article 33E of Chapter 38 of the Illinois Revised Statutes or Section 2-6-12 of the Oak Park Village Code relating to "Proposing Requirement.



David J. Rock, President

(Authorized Agent of bidder selected)

Subscribed and sworn to before me this 14th day of OCTOBER, 2024.



Notary Public's Signature

- Notary Public Seal -





Business Entity Search

Entity Information

Entity Name	IHC CONSTRUCTION COMPANIES, L.L.C.		
Principal Address	385 AIRPORT RD. STE 100 ELGIN, IL 601230000		
File Number	00633127	Status	ACTIVE on 11-29-2023
Entity Type	LLC	Type of LLC	Domestic
Org. Date/Admission Date	12-03-2001	Jurisdiction	IL
Duration	PERPETUAL		
Annual Report Filing Date	11-29-2023	Annual Report Year	2023
Agent Information	MATTHEW P CONNELLY 333 W WACKER DR STE 1900 CHICAGO, IL 60606-2211	Agent Change Date	12-12-2022

Services and More Information

Choose a tab below to view services available to this business and more information about this business.

- Available Services
- Managers**
- Old LLC Name
- Assumed Name
- Series Name
- File History

[Purchase Master Entity Certificate of Good Standing](#)

[Articles of Amendment Effecting A Name Change](#)

[Adopting Assumed Name](#)

[Change of Registered Agent and/or Registered Office](#)



Office of the Secretary of State

213 State Capitol
Springfield, IL 62756

115 S. LaSalle St., Ste. 300
Chicago, IL 60603

800-252-8980 (toll free in Illinois)

217-785-3000 (outside Illinois)

[About Us](#)

[Contact Forms](#)

Quick Links

- [Discrimination Complaint Form](#)
- [Facility Customer Feedback Form](#)
- [Freedom of Information](#)
- [IL Vehicle Hijacking and Motor Vehicle Theft Prevention & Insurance Verification Council](#)
- [Report SSA Scams](#)
- [Rules of the Road](#)
- [Sexual Harassment Complaint](#)
- [Vendor Communication](#)

All Departments

- [Accounting Revenue](#)
- [Administrative Hearings](#)
- [BAIID](#)
- [Budget & Fiscal Management](#)
- [Business Services](#)
- [Communications](#)
- [Court of Claims](#)
- [Driver Services](#)
- [Illinois State Archives](#)
- [Illinois State Library](#)
- [Index](#)
- [Information Technology](#)
- [Inspector General](#)
- [Legislative Affairs](#)
- [Merit Commission](#)
- [Organ/Tissue Donation](#)
- [Personnel](#)
- [Physical Services](#)
- [Secretary of State Police](#)
- [Securities](#)
- [Vehicle Services](#)



Agenda Item Summary

File #: RES 23-361, **Version:** 1

Submitted By

Rob Sproule, Public Works Director

Reviewed By

Ahmad M. Zayyad, Deputy Village Manager / Interim Director of Development Customer Services

Agenda Item Title

A Resolution Approving an Independent Contractor Agreement with IHC Construction Companies, L.L.C. for the 2024 Water Service Line Replacement Program in an Amount Not to Exceed \$500,000.00 With an Option to Renew for Two Additional One-Year Terms and Authorizing its Execution

Overview

This project includes the replacement of the Village's portion of potable lead water service lines throughout the village and whole service line replacements on emergency repairs. As residents replace their portion of the lead water service line with copper pipe, the Village will replace its side. Typically, 30-50 service lines are replaced annually. This agreement will allow the Village to hire a contractor to supplement the efforts of in-house Village staff. The low responsible bidder was IHC Construction Companies, L.L.C.

Recommendation

Adopt the Resolution.

Background

This project involves the replacement of the Village side of the lead water service lines throughout the Village. This project is commonly referred to as the Lead Abatement Program.

The work completed under this contract is intended to supplement work performed by in-house Village staff in the Public Works Department Water and Sewer Division. Locations assigned to the contractor are typically locations that are longer runs, more difficult for the in-house staff to complete or require special equipment or at times when Village staff are committed to other maintenance duties. This replacement work is done in conjunction with a resident upgrading the private side of the service with a plumbing contractor. As lead laws have changed, additional whole service upgrades will be required when an emergency repair needs to be made on the public side of the service.

Competitive bids were opened on Wednesday, October 25, 2023 at 2:00 P.M., for the 2024 Water Service Line Replacement Program (Project # 24-102). The low responsible bid was submitted by IHC Construction Companies, L.L.C. in a base bid amount of \$481,856.00

Staff recommends entering into an Independent contractor agreement with IHC Construction Companies, L.L.C. in an amount not to exceed \$500,000.00.

Fiscal Impact

The proposed Fiscal Year 2024 Budget includes \$500,000.00 to complete water service upgrades in account # 5040-43730-777-570707 (Water & Sewer Fund, Water Distribution, Capital Improvements).

DEI Impact

This project is in alignment with Climate Ready Oak Park Plan Goal: DW06: Identify options to create an equitable and affordable full lead service line replacement program for low- and moderate-income residents. If the line needs to be replaced due to a failure on the Village side of the service, the entire service, both public and private, will be replaced at the expense of the Village.

Alternatives

The Board can delay action to gain additional information.

Previous Board Action

The Board has approved agreements for this annually.

Citizen Advisory Commission Action

N/A

Anticipated Future Actions/Commitments

It is anticipated that the Public Works Department will continue to bring this request to the Village Board annually.

Intergovernmental Cooperation Opportunities

N/A

ORIGINAL**RESOLUTION**

A RESOLUTION APPROVING AN INDEPENDENT CONTRACTOR AGREEMENT WITH IHC CONSTRUCTION COMPANIES, L.L.C. FOR 2024 WATER SERVICE LINE REPLACEMENT PROGRAM IN AN AMOUNT NOT TO EXCEED \$500,000.00 WITH AN OPTION TO RENEW FOR TWO ADDITIONAL ONE-YEAR TERMS AND AUTHORIZING ITS EXECUTION

BE IT RESOLVED by the President and Board of Trustees of the Village of Oak Park, Cook County, State of Illinois ("Village"), in the exercise of their home rule powers, that the Independent Contractor Agreement ("Agreement") with IHC Construction Companies, L.L.C., Inc., for 2024 Water Service Line Replacement Program is approved in an amount not to exceed \$500,000.00 for a one-year term with an option to renew for two additional one-year terms and the Village Manager is authorized to execute the Agreement in substantially the form attached.

THIS RESOLUTION shall be in full force and effect from and after its adoption and approval as provided by law.

ADOPTED this 4th day of December, 2023, pursuant to a roll call vote as follows:

Voting	Aye	Nay	Abstain	Absent
President Scaman	✓			
Trustee Buchanan	✓			
Trustee Enyia				✓
Trustee Parakkat	✓			
Trustee Robinson	✓			
Trustee Straw	✓			
Trustee Wesley	✓			

APPROVED this 4th day of December, 2023.

Vicki Scaman

Vicki Scaman, Village President

ATTEST

Christina M. Waters

Christina M. Waters, Village Clerk

ORIGINAL



INDEPENDENT CONTRACTOR AGREEMENT

THIS INDEPENDENT CONTRACTOR AGREEMENT (hereinafter referred to as the “Contract” or “Agreement”) is entered into on this 12th day of December, 2023, between the Village of Oak Park, an Illinois home rule municipal corporation (hereinafter referred to as the “Village”), and IHC Construction Companies, L.L.C., an Illinois limited liability company (hereinafter referred to as the “Contractor”).

WHEREAS, Contractor submitted a Bid dated October 25, 2023 a copy of which is attached hereto and incorporated herein by reference, to provide services for the 2024 Water Service Line Replacement Program (hereinafter referred to as the “Work”) pursuant to the Village’s Request for Bids dated October 4, 2023, incorporated herein by reference as though fully set forth; and

WHEREAS, the Contractor represented in said Bid that it has the necessary personnel, experience, and competence to promptly complete the Project and the work required hereunder; and

WHEREAS, it is the intent of the Village and Contractor that the Contractor shall perform the Work pursuant to the terms and conditions of this Contract.

NOW, THEREFORE, in consideration of the premises and the mutual promises contained in this Contract, and other good and valuable consideration received and to be received, it is mutually agreed by and between the parties as follows:

1. RECITALS INCORPORATED

The above recitals are incorporated herein as though fully set forth.

2. SCOPE OF WORK

The Contractor shall perform the Project in accordance with its Bid in an amount not to exceed \$500,000.00 (“Contract Price”). The Contractor shall complete the Work in accordance with any applicable manufacturers’ warranties and in accordance with the Village’s Request for Bids, the Contractor’s Bid and this Contract, all of which together shall constitute the “Contract Documents.” The Contractor acknowledges that it has inspected the sites where the Work is to be performed and that it is fully familiar with all of the conditions at the sites, and further that its Bid has adequately taken into consideration all of the conditions at the sites. The Contractor hereby represents and

warrants that it has the skill and experience necessary to complete the Work in a good and workmanlike manner in accordance with the Contract Documents, and that the Work shall be free from defects.

The Contractor shall achieve completion of all work required pursuant to the Contract Documents ("Contract Time"). The Contract Time is of the essence. The Contractor shall have no claim for damages, for compensation in excess of the Contract Price, or for a delay or extension of the Contract Time based upon conditions found at, or in the vicinity of, the site.

3. DESIGNATED REPRESENTATIVES

The Contractor shall designate in writing a person to act as its designated representative with respect to the Work to be performed under this Contract who shall have the power and authority to make or grant or do all things, certificates, requests, demands, approvals, consents, notices and other actions required that are ministerial in nature or described in this Agreement for and on behalf of Contractor and with the effect of binding Contractor. The Village is entitled to rely on the full power and authority of the person executing this Contract on behalf of Contractor as having been properly and legally given by Contractor. Contractor shall have the right to change its designated representative by providing the Village with written notice of such change which notice shall be sent in accordance with Section 13 of this Agreement.

The Village's Public Works Director or the Director's designee shall be deemed the Village's authorized representative for purposes of this Agreement, unless applicable law requires action by the Corporate Authorities, and shall have the power and authority to make or grant or do those things, certificates, requests, demands, approvals, consents, notices and other actions required that are ministerial in nature or described in this Agreement for and on behalf of the Village and with the effect of binding the Village as limited by this Contract. Contractor is entitled to rely on the full power and authority of the person executing this Agreement on behalf of the Village as having been properly and legally given by the Village. The Village shall have the right to change its authorized representative by providing Contractor with written notice of such change which notice shall be sent in accordance with Section 13 of this Agreement.

4. TERM OF CONTRACT, CONTRACT RENEWAL, AND RATE ADJUSTMENT

The Contractor shall perform the Work pursuant to this Contract beginning on the effective date as defined herein and shall expire on December 31, 2024.

The Village will have the right to renew this Contract for two (2) additional one (1) year terms with all terms and conditions, other than price, remaining the same. The Village will allow the Contractor to increase or decrease the contract price for each annual renewal.

Upon written request from the Contractor, on or before October 20 of each year of this Agreement, the cost of the services provided under the Agreement may be adjusted as follows:

The Contractor shall submit a request for adjustment to the Village based upon the average of the published monthly Index (as defined below) for the period October through September for the previous year. The Index shall be the United States Department of Labor, Bureau of Labor Chicago Statistics, Revised Consumer Price Index for all Urban Wage Earners for Chicago-Naperville-Elgin, IL-IN-WI (all items, 1982-84 = 100).

Notwithstanding anything contained in this Contractor to the contrary, an annual adjustment shall not be greater than five percent (5.0%) of the previous year's cost for services provided under this Agreement in any year. Any applicable adjustment shall take effect on January 1st.

5. PAYMENT SCHEDULE

Contractor shall, as a condition precedent to its right to receive any payment, submit to the Village an application for payment and such receipts, vouchers, and other documents as may be necessary to establish the Contractor's payment for all labor and material and the absence of any interest whether in the nature of a lien or otherwise of any party in any property, work, or fund with respect to the Work performed hereunder. Such documents shall include, where relevant, the following forms, copies of which are attached hereto:

- (i) Contractor's sworn statement;
- (ii) Contractor's partial or final waiver of lien;
- (iii) Subcontractor's sworn statement(s); and
- (iv) Subcontractor's partial or final waiver of lien.

Payment by the Village shall be conditioned upon an inspection by the Village of the Work completed and submission of required waivers by the Contractor. Payment by the Village shall in no way constitute a waiver of, or relieve the Contractor from, any defects in the work. All payments shall be made in accordance with the Illinois Local Government Prompt Payment Act, 50 ILCS 505/1 *et seq.* Final payment for any Work performed by the Contractor pursuant to an invoice by Contractor shall be made by the Village to the Contractor when Contractor has fully performed the work and the work has been approved by the Village and submission of required waivers and paperwork by Contractor. Approval of the work and issuance of the final payment by the Village shall not constitute a waiver of, or release Contractor from, any defects in the work.

The Village shall have the right to withhold from any payment due hereunder such amount as may reasonably appear necessary to compensate the Village for any actual or prospective loss due to Work which is defective or does not conform to the Contract Documents; damage

for which Contractor is liable hereunder; liens or claims of liens; claims of third parties, subcontractors, or material men; or any failure of the Contractor to perform any of its obligations under this Contract. The Village may apply any money withheld or due Contractor hereunder to reimburse itself for any and all costs, expenses, losses, damages, liabilities, suits, judgments, awards, and attorney's fees incurred, suffered, or sustained by the Village and chargeable to Contractor.

6. TERMINATION

The Village may terminate this Contract for cause, which includes but is not necessarily limited to, the Contractor's failure to perform the work pursuant to this Contract. The Village shall provide the Contractor with five (5) days' written notice of a termination for cause pursuant to the provisions of Section 13 below. The Village may also terminate this Contract when it determines the same to be in its best interests by giving fourteen (14) days' written notice to the Contractor pursuant to the provisions of Section 13 below. In such event, the Village shall pay to the Contractor all amounts due for the work performed up to the date of termination.

7. DEFAULT/THE VILLAGE'S REMEDIES.

If it should appear at any time prior to payment for the Work provided pursuant to this Contract that the Contractor has failed or refused to prosecute, and is in default, or has delayed in the prosecution of, the Work to be provided pursuant to this Contract with diligence at a rate that assures completion of the Work in full compliance with the requirements of this Contract, or has attempted to assign this Contract or the Contractor's rights under this Contract, either in whole or in part, or has falsely made any representation or warranty, or has otherwise failed, refused, or delayed to perform or satisfy any other requirement of this Contract or has failed to pay its debts as they come due ("Event of Default"), and has failed to cure, or has reasonably commenced to cure any such Event of Default within fifteen (15) business days after Contractor's receipt of written notice of such Event of Default, then the Village shall have the right, at its election and without prejudice to any other remedies provided by law or equity, to pursue any one or more of the following remedies:

(A) The Village may require Contractor, within such reasonable time as may be fixed by the Village, to complete or correct all or any part of the Work that are defective, damaged, flawed, unsuitable, nonconforming, or incomplete and to take any or all other action necessary to bring Contractor and the Work into compliance with this Contract;

(B) The Village may accept the defective, damaged, flawed, unsuitable, nonconforming, incomplete, or dilatory Work or part thereof and make an equitable reduction;

(C) The Village may terminate this Contract without liability for further payment of amounts due or to become due under this Contract except for amounts due for Services properly performed prior to termination;

(D) The Village may withhold any payment from Contractor, whether or not previously approved, or may recover from Contractor any and all costs, including attorneys' fees and administrative expenses, incurred by the Village as the result of any Event of Default or as a result of actions taken by the Village in response to any Event of Default; or

(E) The Village may recover any damages suffered by the Village as a result of Contractor's Event of Default.

(F) In addition to the above, if Contractor fails to complete any required Work pursuant to this Contract, the Village shall be entitled to liquidated damages in the amount of five hundred dollars (\$500.00) per day for each day the Services remains uncompleted. This amount is not a penalty, and the parties agree to said amount given the difficulties associated with determining or calculating damages to the Village in the event the required Work is not completed on time.

8. COMPLIANCE WITH APPLICABLE LAWS

Contractor shall comply with all applicable laws, regulations, and rules promulgated by any federal, state, county, municipal and/or other governmental unit or regulatory body now in effect during the performance of the work. By way of example only and not as a limitation, the following are included within the scope of the laws, regulations and rules with which the Contractor must comply: all forms of workers' compensation Laws, all terms of the equal employment opportunity rules and regulations of the Illinois Department of Human Rights, statutes relating to contracts let by units of government, and all applicable civil rights and anti-discrimination laws and regulations.

9. INDEMNIFICATION

To the fullest extent permitted by law, the Contractor shall waive any right of contribution against the Village and shall indemnify and hold harmless the Village and its officers, officials, employees, volunteers and agents from and against all claims, damages, losses and expenses, including, but not limited to, legal fees (attorney's and paralegal's fees, expert fees and court costs) arising out of or resulting from the performance of the Contractor's work, provided that any such claim, damage, loss or expense is attributable to bodily injury, sickness, disease or death, or injury to or destruction of property, other than the work itself, including the loss of use resulting therefrom, or is attributable to misuse or improper use of trademark or copyright-protected material or otherwise protected intellectual property, to the extent it is caused in whole or in part by any wrongful or negligent act or omission of Contractor, any subcontractor, anyone directly

or indirectly employed by any of them or anyone for whose acts any of them may be liable. Such obligation shall not be construed to negate, abridge or otherwise reduce any other right to indemnity which the Village would otherwise have. The Contractor shall similarly protect, indemnify and hold and save harmless, the Village, its officers, officials, employees, volunteers and agents against and from any and all claims, costs, causes, actions and expenses, including, but not limited to, legal fees incurred by reason of the Contractor's breach of any of its obligations under, or Contractor's default of, any provisions of this Contract. The indemnification obligations under this Section shall not be limited in any way by any limitation on the amount or type of damages, compensation, or benefits payable by or for the Contractor or any subcontractor under workers' compensation or disability benefit acts or employee benefit acts.

10. INSURANCE

The Contractor shall at the Contractor's expense secure and maintain in effect throughout the duration of this Contract, insurance of the following kinds and limits set forth in this Section. Contractor shall furnish "Certificates of Insurance" to the Village before beginning work on the Project pursuant to this Contract. All insurance policies shall be written with insurance companies licensed to do business in the State of Illinois and having a rating of at least A according to the latest edition of the Best's Key Rating Guide; and shall include a provision preventing cancellation of the insurance policy unless thirty (30) days prior written notice is given to the Village. This provision shall also be stated on each Certificate of Insurance: "Should any of the above described policies be canceled before the expiration date, the issuing company shall mail fifteen thirty (30) days written notice to the certificate holder named to the left."

The limits of liability for the insurance required shall provide coverage for not less than the following amounts, or greater where required by law:

(A) Commercial General Liability:

i. Coverage to include Broad Form Property Damage, Contractual and Personal Injury.

ii. Limits:

General Aggregate	\$ 2,000,000.00
Each Occurrence	\$ 1,000,000.00
Personal Injury	\$ 1,000,000.00

iii. Coverage for all claims arising out of the Contractor's operations or premises and anyone directly or indirectly employed by the Contractor.

(B) Workers' Compensation:

i. Workers' compensation insurance shall be provided in accordance with the provisions of the laws of the State of Illinois, including occupational disease provisions, for all employees who perform the Work pursuant to this Contract, and if work is subcontracted pursuant to the provisions of this Contract, Contractor shall require each subcontractor similarly to provide workers' compensation insurance. In case employees engaged in hazardous work under this Contract are not protected under the Workers' Compensation Act, Contractor shall provide, and shall cause each subcontractor to provide, adequate and suitable insurance for the protection of employees not otherwise provided.

(C) Comprehensive Automobile Liability:

i. Comprehensive Automobile Liability coverage shall include all owned, hired, non-owned vehicles, and/or trailers and other equipment required to be licensed, covering personal injury, bodily injury and property damage.

ii. Limits:
Combined Single Limit \$1,000,000.00

(D) Umbrella:

i. Limits:
Each Occurrence/Aggregate \$5,000,000.00

(E) The Village, its officers, officials, employees, agents and volunteers shall be named as additional insureds on all insurance policies set forth herein except Workers' Compensation. The Contractor shall be responsible for the payment of any deductibles for said insurance policies. The coverage shall contain no special limitations on the scope of protection afforded to the Village, its officers, officials, employees, agents, and volunteers.

(F) The Contractor understands and agrees that any insurance protection required by this Contract or otherwise provided by the Contractor, shall in no way limit the responsibility to indemnify, keep and save harmless, and defend the Village, its officers, officials, employees, agents and volunteers as herein provided. The Contractor waives and shall have its insurers waive, its rights of subrogation against the Village, its officers, officials, employees, agents and volunteers.

11. GUARANTY

The Contractor warrants and guarantees that its Work provided for the Project to be performed under this Contract, and all workmanship, materials, equipment, and supplies performed, furnished, used, or installed under this Contract, performed, furnished, used, or installed under this Contract, shall be free from defects and flaws in workmanship or design; shall strictly conform to the requirements of this Contract; and shall be fit and sufficient for the purposes expressed in, or reasonably inferred from, this Contract. Contractor further warrants and guarantees that the strength of all parts of all manufactured materials, equipment, and supplies shall be adequate and as specified and that the performance requirements of this Contract shall be fulfilled.

Contractor shall, at no expense to the Village, correct any failure to fulfill the above guaranty that may appear at any time. In any event, the guaranty herein expressed shall not be sole and exclusive, and is additional to any other guaranty or warranty expressed or implied.

12. AFFIDAVIT OR CERTIFICATE

The Contractor shall furnish any affidavit or certificate in connection with the work covered by this Contract as required by law.

13. NOTICES

Any notice required to be given by this Contract shall be deemed sufficient if made in writing and sent by certified mail, return receipt requested, by personal service, or by email transmission to the persons and addresses indicated below or to such addresses and persons as either party hereto shall notify the other party of in writing pursuant to the provisions of this Section:

To the Village:

Village Manager
 Village of Oak Park
 123 Madison Street
 Oak Park, Illinois 60302-4272
 Email: villagemanager@oak-park.us

To Contractor:

David Rock, President
 IHC Construction Companies, L.L.C.
 385 Airport Road, Suite 100
 Elgin, Illinois 60123
 Email: utility@ihcconstruction.com

Mailing of such notice as and when above provided shall be equivalent to personal notice and shall be deemed to have been given at the time of mailing. Notice by email transmission shall be effective as of date and time of transmission, provided that the notice transmitted shall be sent on business days during business hours (9:00 a.m. to 5:00 p.m. Chicago time). In the event email notice is transmitted during non-business hours, the effective date and time of notice is the first hour of the first business day after transmission.

14. AUTHORITY TO EXECUTE

The individuals executing this Contract on behalf of Contractor and the Village represent that they have the legal power, right, and actual authority to bind their respective parties to the terms and conditions of this Contract.

15. EFFECTIVE DATE

The effective date of this Contract as reflected above and below shall be the last date of its execution by one of the Parties as set forth below.

16. ENTIRE CONTRACT; APPROVAL OF SUBCONTRACTORS

This Contract, including the documents incorporated by reference herein, sets forth the entire Contract between the parties with respect to the accomplishment of the Work. No right or interest in this Contract shall be assigned, in whole or in part, by either party without the prior written consent of the other party. The Village reserves the right to approve the use of subcontractors to complete any portion of the Work and to approve any applicable contract between the Contractor and a proposed subcontractor to perform any of the Work. This Contract shall be binding upon the parties and upon their respective heirs, executors, administrators, personal representatives, successors, and assigns, except as herein provided.

17. INDEPENDENT CONTRACTOR

The Contractor shall have the full control of the ways and means of performing the Work referred to above and that the Contractor and its employees, representatives or subcontractors are not employees of the Village, it being specifically agreed that the Contractor bears the relationship of an independent contractor to the Village. The Contractor shall solely be responsible for the payment of all salaries, benefits and costs of supplying personnel for the Work.

18. CONTRACT BOND

Before commencing the work on the Project, Contractor shall furnish a Contract Bond. The Contract Bond shall be in an amount of \$50,000.00 as security for the faithful performance of its obligations pursuant to the Contract Documents and as security for the payment of all persons performing labor and furnishing materials in connection with the Contract Documents. Such bond shall be on a standard AIA document, shall be issued by a surety satisfactory to the Village, and shall name the Village as a primary co-obligee. The Contract Bond shall become a part of the Contract Documents. The failure of Contractor to supply the required Contract Bond within ten (10) days after the Notice of Award or within such extended period as the Village may grant if the Contract Bond does not meet its approval shall constitute a default, and the Village may either award the

Contract to the next lowest qualified bidder or re-advertise for bids. A charge against Contractor may be made for the difference between the amount of Contractor's Bid and the amount for which a contract for the Work is subsequently executed, irrespective of whether the amount thus due exceeds the amount of the bid guarantee.

19. PREVAILING WAGES

Contractor and any applicable subcontractor shall pay prevailing wages as established by the Illinois Department of Labor and determined by the Village for each craft or type of work needed to execute the contract in accordance with the Illinois Prevailing Wage Act, 820 ILCS 130/0.01 *et seq.* ("Act"). Contractor shall prominently post the current schedule of prevailing wages at the Project site(s) and shall notify immediately in writing all of its subcontractors of all changes in the schedule of prevailing wages. Any increases in costs to Contractor due to changes in the prevailing rate of wage during the terms of any Contract shall be at the sole expense of Contractor and not at the expense of the Village, and shall not result in an increase to the Contract Price. Contractor shall be solely responsible to maintain accurate records as required by the Act and shall submit certified payroll records to the Village evidencing its compliance with the Act on no less than a monthly basis as required by the Act. Contractor shall be solely liable for paying the difference between prevailing wages and any wages actually received by laborers, workmen and/or mechanics engaged in the Work for the Project.

Contractor shall indemnify, hold harmless, and defend the Village, its officers, officials, employees, agents and volunteers ("Indemnified Parties") against all regulatory actions, complaints, damages, claims, suits, liabilities, liens, judgments, costs and expenses, including reasonable attorney's fees, which may in any way arise from or accrue against the Indemnified Parties as a consequence of noncompliance with the Act or which may in any way result therefrom, including a complaint by the Illinois Department of Labor under Section 4(a-3) of the Act, 820 ILCS 130/4(a-3) that any or all of the Indemnified Parties violated the Act by failing to give proper notice to the Grantee or any other party performing work on the Public Improvements that not less than the prevailing rate of wages shall be paid to all laborers, workers and mechanics performing Work on the Project, including interest, penalties or fines under Section 4(a-3). The indemnification obligations of this section on the part of Contractor shall survive the termination or expiration of this Agreement. In any such claim, complaint or action against the Indemnified Parties, Contractor shall, at its own expense, appear, defend and pay all charges of reasonable attorney's fees and all reasonable costs and other reasonable expenses arising therefrom or incurred in connection therewith, and, if any judgment or award shall be rendered against the Indemnified Parties in any such action, Contractor shall at its own expense, satisfy and discharge such judgment or award.

20. GOVERNING LAW AND VENUE

This Contract shall be governed by the laws of the State of Illinois both as to interpretation and performance. Venue for any action pursuant to this Contract shall be in the Circuit Court of Cook County, Illinois.

21. AMENDMENTS AND MODIFICATIONS

This Contract may be modified or amended from time-to-time provided, however, that no such amendment or modification shall be effective unless reduced to writing and duly authorized and signed by the authorized representative of the Village and the authorized representative of the Contractor.

22. NON-WAIVER OF RIGHTS

No failure of either party to exercise any power given to it hereunder or to insist upon strict compliance by the other party with its obligations hereunder, and no custom or practice of the parties at variance with the terms hereof, nor any payment under this Contract shall constitute a waiver of either party's right to demand exact compliance with the terms hereof.

23. CONFLICT

In case of a conflict between any provision(s) of the Village's Request for Bids or the Contractor's Bid and this Contract, this Contract and the Village's Request for Bids shall control to the extent of such conflict.

24. HEADINGS AND TITLES

The headings and titles provided in this Contract are for convenience only and shall not be deemed a part of this Contract.

25. COOPERATION OF THE PARTIES

The Village and the Contractor shall cooperate in the provision of the Work to be provided by Contractor pursuant to this Contract and in compliance with applicable laws, including, but not limited to, the Illinois Freedom of Information Act, 5 ILCS 140/1 *et seq.* ("FOIA"), and the provision of any documents and information pursuant to a FOIA request. Contractor shall provide any and all responsive documents to the Village pursuant to a FOIA request at no cost to the Village.

26. CERTIFIED PAYROLL

Contractor shall be solely responsible to maintain accurate records reflecting its payroll for its employees who perform any of the Work for the Village pursuant to this Contract and shall submit certified payroll records to the Village's Director of Public Works at any time during the term of this Contract. Contractor shall provide said certified payroll records within seven (7) days upon the request of the Director of Public Works.

27. COUNTERPARTS; FACSIMILE OR PDF SIGNATURES

This Contract may be executed in counterparts, each of which shall be considered an original and together shall be one and the same Contract. A facsimile or pdf copy of this Agreement and any signature(s) thereon will be considered for all purposes as an original.

28. EQUAL OPPORTUNITY EMPLOYER

Contractor is an equal opportunity employer and the requirements of 44 Ill. Adm. Code 750 APPENDIX A and Chapter 13 ("Human Rights") of the Oak Park Village Code are incorporated herein by reference.

The Contractor shall not discriminate against any employee or applicant for employment because of race, sex, gender identity, gender expression, color, religion, ancestry, national origin, veteran status, sexual orientation, age, marital status, familial status, source of income, disability, housing status, military discharge status, or order of protection status or physical or mental disabilities that do not impair ability to work, and further that it will examine all job classifications to determine if minority persons or women are underutilized and will take appropriate affirmative action to rectify any such underutilization. The Contractor shall comply with all requirements of Chapter 13 ("Human Rights") of the Oak Park Village Code.

In the event of the Contractor's noncompliance with any provision of Chapter 13 ("Human Rights") of the Oak Park Village Code, the Illinois Human Rights Act or any other applicable law, the Contractor may be declared non-responsible and therefore ineligible for future Agreements or subcontracts with the Village, and the Agreement may be cancelled or voided in whole or in part, and such other sanctions or penalties may be imposed or remedies invoked as provided by statute or regulation.

In all solicitations or advertisements for employees placed by it on its behalf, the Contractor shall state that all applicants will be afforded equal opportunity without discrimination because of race, sex, gender identity, gender expression, color, religion, ancestry, national origin, veteran status, sexual orientation, age, marital status, familial status, source of income, disability, housing status, military discharge status, or order of protection status or physical or mental disabilities that do not impair ability to work.

29. STANDARD OF CARE

The Contractor shall endeavor to perform the Services with the same skill and judgment which can be reasonably expected from similarly situated firms or entities.

The Contractor shall comply with all federal, state, and local statutes, regulations, rules, ordinances, judicial decisions, and administrative rulings applicable to its performance under this Agreement as applicable, including, but not limited to, Cook County's minimum wage and sick leave ordinances, respectively Cook County Ordinance Number 16-5768 and Cook County Ordinance Number 16-4229, and the Village's Living Wage Ordinance, Village of Oak Park Ordinance Number 16-093, codified as Section 2-6-20 of the Village Code, all as amended.

The Contractor shall ensure that the Services are provided, performed, and completed in accordance with all applicable statutes, ordinances, rules, and regulations, including, but not limited to, the Fair Labor Standards Act; any statutes regarding qualification to do business; any statutes prohibiting discrimination because of, or requiring affirmative action based on race, color, religion, sex, national origin, ancestry, age, order of protection status, marital status, physical or mental disability, military status, sexual orientation, or unfavorable discharge from military service or other prohibited classification, including, without limitation, the Americans with Disabilities Act of 1990, 42 U.S.C. §§ 12101 *et seq.*, and the Illinois Human Rights Act, 775 ILCS 5/1-101 *et seq.* The Contractor shall also comply with all conditions of any federal, state, or local grant received by the Village or the Contractor with respect to this Agreement.

**[REMAINDER OF PAGE INTENTIONALLY LEFT BLANK -
SIGNATURE PAGE FOLLOWS]**

IN WITNESS WHEREOF, the parties hereto have caused this Contract to be signed by their duly authorized representatives on the dates set forth below.

VILLAGE OF OAK PARK

By: Kevin J. Jackson
Its: Village Manager

Date: December 5, 2023

IHC CONSTRUCTION COMPANIES, L.L.C.

By: David J. Rock
Its: President

Date: December 12, 2023

ATTEST

By: Christina M. Waters
Its: Village Clerk

Date: _____, 2023

ATTEST

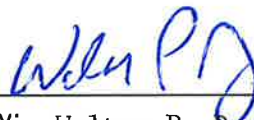
By: Walter P. Dwyer
Its: Secretary

Date: December 12, 2023

**REVIEWED AND APPROVED
AS TO FORM**

DEC 04 2023
LAW DEPT & CLERK



Document A312™ - 2010

Performance Bond

Bond# 30191997

CONTRACTOR:

(Name, legal status and address)
IHC Construction Companies, L.L.C.
385 Airport Road, Suite 100
Elgin, IL

SURETY:

(Name, legal status and principal place of business)
Continental Casualty Company
151 North Franklin Street
Chicago, IL 60606

OWNER:

(Name, legal status and address)
Village of Oak Park
123 Madison St.
Oak Park, IL 60302

This document has important legal consequences. Consultation with an attorney is encouraged with respect to its completion or modification.

Any singular reference to Contractor, Surety, Owner or other party shall be considered plural where applicable.

AIA Document A312-2010 combines two separate bonds, a Performance Bond and a Payment Bond, into one form. This is not a single combined Performance and Payment Bond.

CONSTRUCTION CONTRACT

Date: December 12, 2023

Amount: \$50,000.00

Description:

(Name and location)
2024 Water Service Line Replacement Program- For a Period from 01/01/2024 to 12/31/2024

BOND

Date: January 1, 2024
(Not earlier than Construction Contract Date)

Amount: \$50,000.00

Modifications to this Bond: None See Section 16

CONTRACTOR AS PRINCIPAL

Company: (Corporate Seal)
IHC Construction Companies, L.L.C.

Signature: 
Name David J. Rock
and Title: President
(Any additional signatures appear on the last page of this Performance Bond.)

SURETY

Company: (Corporate Seal)
Continental Casualty Company

Signature: 
Name Courtney A Flaska, Attorney In Fact
and Title:

(FOR INFORMATION ONLY - Name, address and telephone)

AGENT or BROKER:

DS&P Insurance Services, Inc.
1900 E. Golf Road, Suite 650
Schaumburg, IL 60173
(847) 934-6100

OWNER'S REPRESENTATIVE:

(Architect, Engineer or other party:)

LEGAL NOTICE

The Village of Oak Park will receive sealed bids from qualified contractors at the Public Works Center, 201 South Boulevard, Oak Park, Illinois 60302 Monday through Friday, 7:30 a.m. to 4:00 p.m. local time until **2:00 p.m. on Wednesday, October 25, 2023** for the following:

Village of Oak Park
2024 Water Service Line Replacement Program
Bid Number: 24-102

Bid documents may be obtained from the Village's website at <http://www.oak-park.us/bid>. For questions, please call Public Works at (708) 358-5700 during the above hours.

VILLAGE OF OAK PARK, ILLINOIS - BID # 24-102

2024 WATER SERVICE LINE REPLACEMENT

BID OPENING: October 25, 2023 @ 2:00 PM

<u>FIRM:</u>	<u>BID BOND</u>	<u>PRICE</u>
Construction by Camco	yes	\$ 681,421.64
K.L.F. Enterprises, Inc	yes	\$ 698,553.00
United Enterprise LLC	yes	\$ 896,105.00
IHC Construction Companies	yes	\$ 481,856.00
Joel Kennedy Constructing Corp	yes	\$ 1,287,545.00
Millennium Contracting Co	yes	\$ 599,756.00
ENGINEER'S ESTIMATE		\$ 550,090.00

IV
BID FORM (Pricing)

The undersigned bidder agrees to all terms and conditions of the preceding specifications for 2024 Water Service Line Replacement Program and will furnish all the insurance documents and security deposits as stipulated. The unit prices listed below should be for 2024 only. Bid bond amount should be 10% of the sum of Bidder's Estimate amount listed below.

VILLAGE OF OAK PARK 2024 WATER SERVICE LINE REPLACEMENT PROGRAM PROJECT # 24-					
ITEM #	ITEM DESCRIPTION	QUANTITY	UNITS	UNIT PRICE	COST
1	TRENCH BACKFILL	750	CU.YD.	\$110.00	\$82,500.00
2	PROJECT MANAGEMENT(PUBLIC SIDE)	40	HRS	\$114.00	\$4,560.00
3	UTILITY LOCATION - PRIVATE PROPERTY	20	EACH	\$304.20	\$6,084.00
4	UTILITY CONFLICT POTHOLE	5	EACH	\$1,207.00	\$6,035.00
5	SERVICE CONNECTION TO WATER MAIN EXCAVATION	50	EACH	\$2,710.00	\$135,500.00
6	PARKWAY EXCAVATION	20	EACH	\$1,867.00	\$37,340.00
7	WATER SERVICE DISCONNECTION EXCAVATION	5	EACH	\$2,819.40	\$14,097.00
8	WATER SERVICE CONNECTION-PRIVATE PROPERTY	20	EACH	\$1,880.00	\$37,600.00
9	WATER SERVICE LINE, OPEN CUT, 1"	30	LIN.FT.	\$175.00	\$5,250.00
10	WATER SERVICE LINE, OPEN CUT, 1-1/2"	30	LIN.FT.	\$201.00	\$6,030.00
11	WATER SERVICE LINE, OPEN CUT, 2"	30	LIN.FT.	\$205.00	\$6,150.00
12	WATER SERVICE LINE, DIRECTIONAL DRILL, 1"	2125	LIN.FT.	\$42.92	\$91,205.00
13	WATER SERVICE LINE, DIRECTIONAL DRILL, 1-1/2"	450	LIN.FT.	\$54.42	\$24,489.00
14	WATER SERVICE LINE, DIRECTIONAL DRILL, 2"	30	LIN.FT.	\$138.00	\$4,140.00
15	WATER METER RELOCATION	2	EACH	\$700.00	\$1,400.00
16	WATER SERVICE LINE TYPE L 3/4"	40	LIN.FT.	\$24.00	\$960.00
17	WATER SERVICE LINE TYPE L 1"	40	LIN.FT.	\$29.00	\$1,160.00
18	REMOVE AND REPLACE HOT WATER HEATER	1	EACH	\$712.00	\$712.00
19	HAND DIG EXCAVATION ALLOWANCE, 5' DEEP	1	EACH	\$3,296.00	\$3,296.00
20	HAND DIG EXCAVATION ALLOWANCE, 6' DEEP	1	EACH	\$4,079.00	\$4,079.00
21	REMOVE AND REPLACE DRAIN TILES	5	LIN.FT.	\$230.00	\$1,150.00
22	REMOVE AND REPLACE SEWER SERVICE LINES	25	LIN.FT.	\$205.00	\$5,125.00
23	LANDSCAPE RESTORATION(PRIVATE PROPERTY)	100	SQ.FT	\$7.26	\$726.00
24	REMOVAL AND DISPOSAL OF CONTAMINATED MATERIAL	7	CU.YD.	\$324.00	\$2,268.00
BIDDER'S ESTIMATE:				\$	481,856.00

David J. Rock

(Print Name of Individual Signing)

 _____, President
 Signed

Illinois Plumbing License #: _____

IV
BID FORM (Pricing)

The undersigned bidder agrees to all terms and conditions of the preceding specifications for 2024 Water Service Line Replacement Program and will furnish all the insurance documents and security deposits as stipulated. The unit prices listed below should be for 2024 only. Bid bond amount should be 10% of the sum of Bidder's Estimate amount listed below.

VILLAGE OF OAK PARK 2024 WATER SERVICE LINE REPLACEMENT PROGRAM PROJECT # 24-					
ITEM #	ITEM DESCRIPTION	QUANTITY	UNITS	UNIT PRICE	COST
1	TRENCH BACKFILL	750	CU.YD.	\$ 110.00	\$ 82,500.00
2	PROJECT MANAGEMENT(PUBLIC SIDE)	40	HRS	\$ 114.00	\$ 4,560.00
3	UTILITY LOCATION - PRIVATE PROPERTY	20	EACH	\$ 304.20	\$ 6,084.00
4	UTILITY CONFLICT POTHOLE	5	EACH	\$ 1,207.00	\$ 6,035.00
5	SERVICE CONNECTION TO WATER MAIN EXCAVATION	50	EACH	\$ 2,710.00	\$ 135,500.00
6	PARKWAY EXCAVATION	20	EACH	\$ 1,867.00	\$ 37,340.00
7	WATER SERVICE DISCONNECTION EXCAVATION	5	EACH	\$ 2,819.40	\$ 14,097.00
8	WATER SERVICE CONNECTION-PRIVATE PROPERTY	20	EACH	\$ 1,880.00	\$ 37,600.00
9	WATER SERVICE LINE, OPEN CUT, 1"	30	LIN.FT.	\$ 175.00	\$ 5,250.00
10	WATER SERVICE LINE, OPEN CUT, 1-1/2"	30	LIN.FT.	\$ 201.00	\$ 6,030.00
11	WATER SERVICE LINE, OPEN CUT, 2"	30	LIN.FT.	\$ 205.00	\$ 6,150.00
12	WATER SERVICE LINE, DIRECTIONAL DRILL, 1"	2125	LIN.FT.	\$ 42.92	\$ 91,205.00
13	WATER SERVICE LINE, DIRECTIONAL DRILL, 1-1/2"	450	LIN.FT.	\$ 54.42	\$ 24,489.00
14	WATER SERVICE LINE, DIRECTIONAL DRILL, 2"	30	LIN.FT.	\$ 138.00	\$ 4,140.00
15	WATER METER RELOCATION	2	EACH	\$ 700.00	\$ 1,400.00
16	WATER SERVICE LINE TYPE L 3/4"	40	LIN.FT.	\$ 24.00	\$ 960.00
17	WATER SERVICE LINE TYPE L 1"	40	LIN.FT.	\$ 29.00	\$ 1,160.00
18	REMOVE AND REPLACE HOT WATER HEATER	1	EACH	\$ 712.00	\$ 712.00
19	HAND DIG EXCAVATION ALLOWANCE, 5' DEEP	1	EACH	\$ 3,296.00	\$ 3,296.00
20	HAND DIG EXCAVATION ALLOWANCE, 6' DEEP	1	EACH	\$ 4,079.00	\$ 4,079.00
21	REMOVE AND REPLACE DRAIN TILES	5	LIN.FT.	\$ 230.00	\$ 1,150.00
22	REMOVE AND REPLACE SEWER SERVICE LINES	25	LIN.FT.	\$ 205.00	\$ 5,125.00
23	LANDSCAPE RESTORATION(PRIVATE PROPERTY)	100	SQ.FT	\$ 7.26	\$ 726.00
24	REMOVAL AND DISPOSAL OF CONTAMINATED MATERIAL	7	CU.YD.	\$ 324.00	\$ 2,268.00
BIDDER'S ESTIMATE:				\$ 481,856.00	

David J. Rock

 (Print Name of Individual Signing)

 Signed _____, President

Illinois Plumbing License #: _____

being first duly sworn on oath deposes and says that the bidder on the above Bid is organized as indicated below and that all statements herein made on behalf of such bidder and that their deponent is authorized to make them, and also deposes and says that deponent has examined and carefully prepared their Bid from the Agreement Specifications and has checked the same in detail before submitting this Bid; that the statements contained herein are true and correct.

Signature of bidder authorizes the Village of Oak Park to verify references of business and credit at its option.

Signature of bidder shall also be acknowledged before a Notary Public or other person authorized by law to execute such acknowledgments.

Dated: 10 / 25 / 2023 IHC Construction Companies, LLC
 Organization Name (Seal - If Corporation)

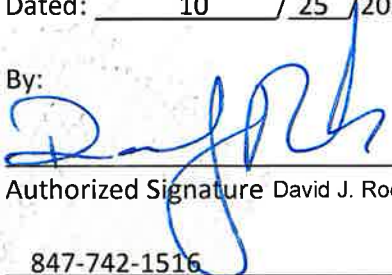
By: 
385 Airport Rd., Suite 100 Elgin, IL 60123
 Authorized Signature David J. Rock, President Address

847-742-1516 Utility@ihcconstruction.com
 Telephone E-mail

Subscribed and sworn to before me this 25th day of October, 2023.

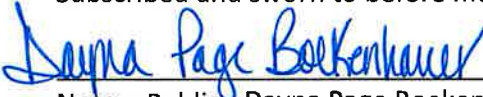
 in the State of ILLINOIS. My Commission
 Notary Public Dayna Page Boekenbauer

Expires on 11 / 29 / 2026





**ACTION BY MEMBERS
IHC CONSTRUCTION COMPANIES, LLC
BY MAJORITY WRITTEN CONSENT**

We, the undersigned, being the majority of the members of IHC Construction Companies, L.L.C., an Illinois Limited Liability Company, hereby consent in writing without a meeting to the following actions:

RESOLVED, that those persons whose names are included below hold the positions set beside their name and those persons are hereby authorized to bind the company and to execute all documents necessary to conduct business on behalf of the limited liability company, including, but not limited to the execution of contracts of all kinds, bids, proposals and bonds.

- | | |
|---------------------|---|
| David J. Rock | Managing Member, Chief Executive Officer,
President, Treasurer |
| Walter P. Dwyer | Member, Chief Operating Officer,
Executive Vice President, Secretary |
| Peter D. Nielsen | Member, Vice President, Assistant Secretary |
| Brian T. Rausch | Member, Vice President, Assistant Secretary |
| Ronald F. Marshall | Chief Financial Officer, Assistant Secretary |
| Russell D. Ginn | Vice President, Assistant Secretary |
| Robert T. Szoch | Vice President, Assistant Secretary |
| Lawrence C. Creadon | Agent, Assistant Secretary |
| Grady Higginbotham | Agent, Assistant Secretary |

WITNESS WHEREOF, we have hereunto set our hands as Members of IHC Construction Companies, L.L.C., this 11th day of July 2023.

DAVID J. ROCK
Managing Member

WALTER P. DWYER
Member

PETER D. NIELSEN
Member

BRIAN T. RAUSCH
Member

**Subscribed and sworn to before me this
11th day of July 2023.**

Notary Public





**OWNERS OF IHC CONSTRUCTION COMPANIES, LLC
MEMBERS OF THE LIMITED LIABILITY COMPANY**

Federal Tax I.D. #: 36-4487367 State IBT#: 3281-0725 DHR #: 113177-00

NAME	ADDRESS
David J. Rock, Managing Member	37W600 York Lane Elgin, IL 60123
Walter P. Dwyer, Member	857 Samantha Circle Geneva, IL 60134
John W. Dwyer, Member	2257 North Wayne Ave., 2D Chicago, IL 60614
Peter D. Nielsen, Member	14475 Eighteenth Fairway Milton, GA 30004
Brian T. Rausch, Member	711 East Suffield Drive Arlington Heights, IL 60004
Matthew D. Rock, Member	3689 Peregrine Way Elgin, IL 60124

Corporate Office: 385 Airport Road, Suite 100, Elgin, IL 60123 • Phone: 847-742-1516 • Fax: 847-742-6610
Utility Division Office/Warehouse & Repair and Fabrication Shop/Yard: 1260 Bell Court Pingree Grove, IL 60140 • Fax: 847-289-3650
Southeast Regional Office: 2700 Delk Road SE Suite 210, Marietta, GA 30067 • Phone: 404-497-7619 • Fax: 404-585-5085

**www.lhcconstruction.com
ESTABLISHED 1906**

File Number

0063312-7



To all to whom these Presents Shall Come, Greeting:

I, Alexi Giannoulas, Secretary of State of the State of Illinois, do hereby certify that I am the keeper of the records of the Department of Business Services. I certify that

IBC CONSTRUCTION COMPANIES, L.L.C., HAVING ORGANIZED IN THE STATE OF ILLINOIS ON DECEMBER 03, 2001, APPEARS TO HAVE COMPLIED WITH ALL PROVISIONS OF THE LIMITED LIABILITY COMPANY ACT OF THIS STATE, AND AS OF THIS DATE IS IN GOOD STANDING AS A DOMESTIC LIMITED LIABILITY COMPANY IN THE STATE OF ILLINOIS.



In Testimony Whereof, I hereto set my hand and cause to be affixed the Great Seal of the State of Illinois, this 24TH day of MAY A.D. 2023 .

Authentication #: 2314402498 verifiable until 05/24/2024
Authenticate at: <https://www.ilsos.gov>

Alexi Giannoulas
SECRETARY OF STATE

BID FORM CONTINUED

Complete Applicable Paragraph Below

(a) ~~Corporation~~ Limited Liability Company

The bidder is a ~~corporation~~ which operates under the legal name of
Limited Liability Company

IHC Construction Companies, LLC and is organized and existing under the laws of the State of
ILLINOIS. The full names of its Officers are:

President David J. Rock

Secretary Walter P. Dwyer

Treasurer David J. Rock

The corporation does have a corporate seal. (In the event that this Bid is executed by a person other than the President, attach hereto a certified copy of that section of Corporate By-Laws or other authorization by the Corporation that permits the person to execute the offer for the corporation.)

(b) Partnership

Names, Signatures, and Addresses of all Partners

The partnership does business under the legal name of _____, which name is registered with the office of _____ in the county of _____

(c) Sole Proprietor

The bidder is a Sole Proprietor whose full name is _____ . If the

bidder is operating under a trade name,

said trade name is _____,

which name is registered with the office of _____

in the county of _____.

Signed: _____

Sole Proprietor

In compliance with the above, the undersigned offers and agrees, if his/her Bid is accepted within ninety (90) calendar days from date of opening, to furnish any or all of the items upon which prices are quoted, at the price set opposite each item, delivered at the designated point within the time specified above.

MUNICIPAL QUALIFICATION REFERENCE SHEET

Bidders shall furnish a minimum of four (4) references from projects similar in scope within the last two (2) years.

MUNICIPALITY PLEASE SEE ATTACHMENT A & B
ADDRESS _____

CONTACT _____
PHONE _____
WORK _____
PERFORMED _____

MUNICIPALITY _____
ADDRESS _____

CONTACT _____
PHONE _____
WORK _____
PERFORMED _____

MUNICIPALITY _____
ADDRESS _____

CONTACT _____
PHONE _____
WORK _____
PERFORMED _____

MUNICIPALITY _____
ADDRESS _____

CONTACT _____
PHONE _____
WORK _____
PERFORMED _____



IHC Construction Companies LLC
UG Utility Reference List

<u>Client/Completion Date</u>	<u>Project Description</u>	<u>Location</u>	<u>Value</u>	<u>Contact</u>	<u>Phone</u>	<u>Email</u>
Village of Streamwood – March 2018	Water Main Installation	Streamwood, IL	\$85,000.00	Alex Riegler	630-736-3850	ariegler@streamwood.org
Morton Grove Niles Water Commission- Dec 2019	Fiber Optic & Tracer Wire Installation	Morton Grove Niles Skokie	\$395,000.00	Jesse Singer	630-770-4971	jsinger@ciorba.com
City of Elmhurst- July 2019	Atrium Lift Station Replacement	Elmhurst, IL	\$1,109,500.00	Tom Foley	262-842-2427	Tom.Foley@clarkdietz.com
City of Lake Forest- Feb 2019	Sanitary Force Main Installation	Lake Forest, IL	\$470,000.00	Bernard Pondexter	847-810-3556	pondextb@cityoflakeforest.com
SNH Medical Office Properties/The RMR Group March 2020	Lakeside Pointe Fire Main Replacement	Waukegan, IL	\$190,125.00	Tyler Reynolds	708-831-4061	treynolds@rmrgroup.com
City of Aurora- April 2020	Water Main Lining & Replacement	Aurora, IL	\$2,000,000.00	Kurt Muth	630-256-3200	kmuth@aurora-il.org
Village of Tinley Park- Nov 2020	Fiber Optic Extension Project	Tinley Park, IL	\$139,700.00	Colby Zemaitis	708-444-5516	czemaitis@tinleypark.org
Village of Wauconda- Nov 2020	ROW Storm Sewer Rehab	Wauconda, IL	\$53,500.00	Chris Bouchard	847-362-5959	cbouchard@rhmg.com
North Shore Water Reclamation District-March 2021	Sewer Lining & Improvements	Skokie, IL	\$189,800.00	Christopher Palmer	847-325-7496	cpalmer@manhard.com

Corporate Office: 385 Airport Rd., Suite 100 Drive, Elgin, IL 60123 • Phone: 847-742-1516 • Fax: 847-742-6610
Utility Division Office/Warehouse & Repair and Fabrication Shop/Yard: 1260 Bell Court, Pingree Grove, IL 60140 • Fax: 847-289-3650
Southeast Regional Office: 2700 Delk Road SE, Suite 210, Marietta, GA 30067 • Phone: 404-497-7619 • Fax: 404-585-5085

ATTACHMENT A

<u>IHC Construction Companies LLC</u>						
<u>UG Utility Reference List</u>						
<u>Client/Completion Date</u>	<u>Project Description</u>	<u>Location</u>	<u>Value</u>	<u>Contact</u>	<u>Phone</u>	<u>Email</u>
City of Sycamore – September-2021	Sanitary Manhole Rehab	Sycamore, IL	\$61,789.00	Mark Bushnell	815-895-4557	mbushnell@cityofsycamore.com
City of St. Charles – March 2022	Concrete Foundation for Substation 3	St. Charles, IL	\$121,395.00	Erika Sittler	630-377-4983	esittler@stcharlesil.gov
City of Oak Creek, WI- May 2022	Rawson Ave Water Extension	Oak Creek, WI	\$654,000.00	Brian Johnston	414-766-6624	bjohnston@oakcreekwi.gov
Village of Hampshire- August 2022	Water Main Replacement #11 Old Mill Manor	Hampshire, IL	\$103,370.00	Tim Paulson	630-466-6727	tpaulson@eeiweb.com
Lake County Public Works-Oct 2022	Force Main Replacement Project	Long Grove, IL	\$602,567.00	David Humbert	847-377-7145	DHumbert@lakecountvil.gov
D.J.K Custom Homes, Inc-Oct 2022	Far Side Services & Lead Service Replacements	Heritage Place 140 N. Wright St. Naperville, IL	\$229,000.00	Bill Bolster- City of Naperville	630-420-4122	bolsterb@naperville.il.us
Lake County Public Works-Mar 2023	RT 83 Force Main Realignment	Long Grove, IL	\$235,650.00	Tom Miles	847-544-8717	tmiles@lakecountvil.gov

Corporate Office: 385 Airport Rd., Suite 100 Drive, Elgin, IL 60123 • Phone: 847-742-1516 • Fax: 847-742-6610
Utility Division Office/Warehouse & Repair and Fabrication Shop/Yard: 1260 Bell Court, Pingree Grove, IL 60140 • Fax: 847-289-3650
Southeast Regional Office: 2700 Delk Road SE, Suite 210, Marietta, GA 30067 • Phone: 404-497-7619 • Fax: 404-585-5085

IHC Construction Companies LLC
UG Utility Division
Contracts on Hand

<u>Client</u>	<u>Project Description</u>	<u>Location</u>	<u>Value</u>	<u>Contact</u>	<u>Phone</u>	<u>Email</u>
City of Elgin	Lead Svc Line Replacements-Yr 2	Various locations in Elgin, IL	\$1,463,116.00	Timo Bello	931-6001 847- 377-7150	Bello_e@cityofelgin.org
Lake County Public Works	Highland Lake Water System	Washington St & Lakeside Dr	\$1,186,060.80	Ying Miao	847-377-7149	ymiao@lakecountvil.gov
Airy's, Inc	Install Water Main & Water Services	SW Chicago Suburbs	\$2,500,000.00	Tom Land	708-429-0660	thomas.land@airys.com
Village of Oak Park	Emergency Water & Sewer Repairs	Oak Park, IL	\$40,000.00	Michael Bills	708-358-5730	mbills@oak-park.us
Village of Grayslake	Emergency Water Main Repairs	Grayslake, IL	\$100,000.00	Nick Nierman	847-223-8515	nnierman@villageofgrayslake.com
City of Naperville	Emergency Excavation & UG Repairs	Naperville, IL	\$40,000.00	Bill Bolster	630-420-4122	BolsterB@naperville.il.us
Zayo Group	Conduit Systems & Cable Installation	Various	\$500,000.00	Tim Payment	630-203-8003	Timothy.payment@zayo.com
Crown Castle Inc.-	Conduit Systems & Cable Installation	Various	\$1,500,000.00	John Pyka	312-955-2252	john.pyka@crowncastle.com
AT&T	Conduit Systems & Cable Installation	Various	\$6,000,000.00	Bobby Akhter	630-719-1230	ba3817@att.com

Corporate Office: 385 Airport Road, Suite 100, Elgin, IL 60123 • Phone: 847-742-1516 • Fax: 847-742-6610
Utility Division Office/Warehouse & Repair and Fabrication Shop/Yard: 1260 Bell Court Pingree Grove, IL 60140 • Fax: 847-289-3650
Southeast Regional Office: 2700 Delk Road SE Suite 210, Marietta, GA 30067 • Phone: 404-497-7619 • Fax: 404-585-5085



Mayor

David J. Kaptain

City Council

Corey D. Dixon

Dustin R. Good

Rosamaria Martinez

Anthony Ortiz

Tish S. Powell

Carol J. Rauschenberger

F. John Steffen

Steven F. Thoren

September 19, 2023

City Manager

Richard G. Kozal

Lawrence Creadon
IHC Construction Companies, LLC
385 Airport Rd., Suite 100
Elgin, IL 60123

Subject: Letter of Recommendation

Dear Mr. Creadon:

I am providing this letter of recommendation for the work that IHC Construction Companies (IHC) has completed on one of the City of Elgin's Lead Service Line Replacement Program contracts in FY2023. This contract involves the removal and replacement of approximately 90 existing residential lead water service lines. The service lines are located in the near-northeast area of the City. The total estimated construction cost for the replacement of the lead service lines was approximately \$1,463,100. IHC is currently on schedule and under budget.

IHC's work has been satisfactorily performed. The City preferred trenchless installation on all service lines unless deemed unfeasible and IHC has been able to meet that expectation using both lead extraction and directional drilling construction methods. Other scope items of this project include resident coordination, pre-construction home assessments, and restoration.

Based on the experience I've had with IHC to date, I would recommend them for lead service line replacement projects. If you have any questions or would like to discuss details of the above-mentioned project, I can be reached at 847-931-6098 or bello_e@cityofelgin.org.

Sincerely,

Timo Bello
City of Elgin
Utilities Superintendent

3/2/23

Re: IHC Construction Company, LLC

To Whom It May Concern:

IHC Construction Co replaced 9 lead water services in Naperville in 2022. All the replacements were long side from a new water main into existing homes, some of the homes had finished basements. IHC is an excellent contractor to work with. From start to finish, from Project Manager Larry Creadon to the field personnel, this team was great to work with. Very conscientious of the work involved, very social with the homeowners and explained everything. They were very neat inside and outside the homes, used plastic and tarps to cover everything. The outside taps and bores were precise, they understand the importance of potholing utilities to assure proper damage control. They kept an open dialogue with the City of Naperville W/WW Utility and also the developer to assure all inspections were met. I spoke daily with the field personnel to discuss timing and schedules, our W/WW customers were kept in the construction loop. They worked safely and neatly outside the homes and made sure open holes were sheeted and barricaded. I would invite IHC to bid lead service line replacements in our City.

From my work experience with IHC, I have nothing negative to relate.

Regards,

William Bolster, City of Naperville

Utility Inspection Supervisor Civil Engineering Division

630-420-4122

V
BIDDER CERTIFICATION

IHC Construction Companies, LLC, as part of its Bid on an agreement for 2024 Water service Line Replacement Program for the Village of Oak Park, hereby certifies that said bidder selected is not barred from proposing on the aforementioned agreement as a result of a violation to either Section 33E-3 or 33E-4 of Article 33E of Chapter 38 of the Illinois Revised Statutes or Section 2-6-12 of the Oak Park Village Code relating to "Proposing Requirement.

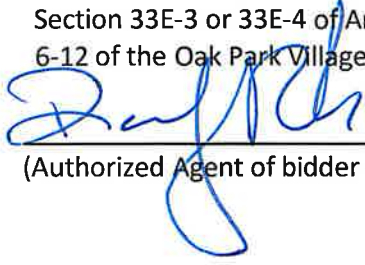

David J. Rock, President

(Authorized Agent of bidder selected)

Subscribed and sworn to before me this 25th day of October, 2023.



Notary Public's Signature
Dayna Page Boekenbauer

- Notary Public Seal -



VI
TAX COMPLIANCE AFFIDAVIT

_____ David J. Rock _____, being first duly sworn, deposes and says:

that he/she is _____ **President** _____ of
(partner, officer, owner, etc.)

_____ **IHC Construction Companies, LLC** _____
(bidder selected)

The individual or entity making the foregoing Bid or proposal certifies that he/she is not barred from entering into an agreement with the Village of Oak Park because of any delinquency in the payment of any tax administered by the Department of Revenue unless the individual or entity is contesting, in accordance with the procedures established by the appropriate revenue act, liability for the tax or the amount of the tax. The individual or entity making the Bid or proposal understands that making a false statement regarding delinquency in taxes is a Class A Misdemeanor and, in addition, voids the agreement and allows the municipality to recover all amounts paid to the individual or entity under the agreement in civil action.



By: David J. Rock
Its: President

David J. Rock, President

(name of bidder if the bidder is an individual)
(name of partner if the bidder is a partnership)
(name of officer if the bidder is a ~~corporation~~)
Limited Liability Company

The above statement must be subscribed and sworn to before a notary public.

Subscribed and sworn to before me this 25th day of October, 2023.



Notary Public's Signature
Dayna Page Boekenhauer

- Notary Public Seal -

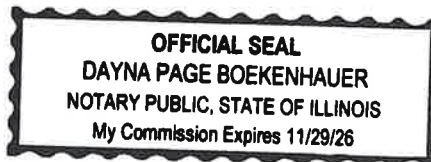

VII
ORGANIZATION OF BIDDING FIRM

Please fill out the applicable section:

Limited Liability Company

A. Corporation:

Limited Liability Company

The Contractor is a ~~corporation~~, legally named IHC Construction Companies, LLC and is organized and existing in good standing under the laws of the State of ILLINOIS. The full names of its Officers are:

President David J. Rock

Secretary Walter P. Dwyer

Treasurer David J. Rock

Registered Agent Name and Address: IHC Construction Companies, LLC- 385 Airport Rd., Suite 100 Elgin, IL 60123

The corporation has a corporate seal. (In the event that this Bid is executed by a person other than the President, attach hereto a certified copy of that section of Corporate By-Laws or other authorization by the Corporation that permits the person to execute the offer for the corporation.)

B. Sole Proprietor:

The Contractor is a Sole Proprietor. If the Contractor does business under an Assumed Name, the Assumed Name is _____, which is registered with the Cook County Clerk. The Contractor is otherwise in compliance with the Assumed Business Name Act, 805 ILCS 405/0.01, et. seq.

C. Partnership:

The Contractor is a Partnership which operates under the name _____

The following are the names, addresses and signatures of all partners:

Signature

Signature

(Attach additional sheets if necessary.) If so, check here _____.

If the partnership does business under an assumed name, the assumed name must be registered with the Cook County Clerk and the partnership is otherwise in compliance with the Assumed Business Name Act, 805 ILCS 405/0.01, et. seq.

D. Affiliates: The name and address of any affiliated entity of the business, including a description of the affiliation: _____

Signature of Owner

SECTION VIII
BID BOND

RE: 2024 Water Service Line
Replacement Program

WE IHC Construction Companies, L.L.C

as PRINCIPAL, and Continental Casualty Company
as SURETY, are held and firmly bound unto the Village of Oak Park, Illinois (hereafter referred to as "VOP") in the penal sum of Ten Percent (10%) of the total bid price, as specified in the invitation for bids. We bind ourselves, our heirs, executors, administrators, successors, and assigns, jointly to pay to the VOP this sum under the conditions of this instrument.

WHEREAS THE CONDITION OF THE FOREGOING OBLIGATION IS SUCH that, the said PRINCIPAL is submitting a written bid to the VOP acting through its awarding authority for the completion of the work designated as the above section.

THEREFORE if the bid is accepted and an agreement awarded to the PRINCIPAL by the VOP for the above-designated section and the PRINCIPAL shall within fifteen (15) days after award enter into a formal agreement, furnish surety guaranteeing the faithful performance of the work, and furnish evidence of the required insurance coverage, all as provided in Specifications then this obligation shall become void; otherwise it shall remain in full force and effect.

IN THE EVENT the VOP determines the PRINCIPAL has failed to enter into a formal agreement in compliance with any requirements set forth in the preceding paragraph, then the VOP acting through its awarding authority shall immediately be entitled to recover the full penal sum set out above, together with all court costs, all attorney fees, and any other expense of recovery.

IN TESTIMONY WHEREOF, the said PRINCIPAL and the said SURETY have caused this instrument to be signed by their respective officers this 25th day of October A.D. 2023.

PRINCIPAL
IHC Construction Companies, L.L.C. _____
(Company Name) (Company Name)
By:  By: _____
(Signature & Title) David J. Rock (Signature & Title)
President

(If PRINCIPAL is a joint venture of two or more Contractors, the company names, and authorized signatures of each Contractor must be affixed)

BID BOND CONTINUED

Subscribed to and Sworn before me on the

25th day of October, 2023.

Notary Public

NAME OF SURETY Continental Casualty Company

By: *Samantha Bradtke*
Signature of Attorney-in-Fact Samantha Bradtke

Subscribed to and Sworn before me on the

25th day of October, 2023.

Laurie A. Bradtke
Notary Public



POWER OF ATTORNEY APPOINTING INDIVIDUAL ATTORNEY-IN-FACT

Know All Men By These Presents, That Continental Casualty Company, an Illinois insurance company, National Fire Insurance Company of Hartford, an Illinois insurance company, and American Casualty Company of Reading, Pennsylvania, a Pennsylvania insurance company (herein called "the CNA Companies"), are duly organized and existing insurance companies having their principal offices in the City of Chicago, and State of Illinois, and that they do by virtue of the signatures and seals herein affixed hereby make, constitute and appoint

James L Sulkowski, R B Schutz, Christine Eitel, Sherene L Hemler, Lucianne Bischoff, Mike Pohl, Kirk Liskiewitz, Courtney A Flaska, Samantha Bradtke, Individually

of Schaumburg, IL, their true and lawful Attorney(s)-in-Fact with full power and authority hereby conferred to sign, seal and execute for and on their behalf bonds, undertakings and other obligatory instruments of similar nature

- In Unlimited Amounts -

and to bind them thereby as fully and to the same extent as if such instruments were signed by a duly authorized officer of their insurance companies and all the acts of said Attorney, pursuant to the authority hereby given is hereby ratified and confirmed.

This Power of Attorney is made and executed pursuant to and by authority of the By-Law and Resolutions, printed on the reverse hereof, duly adopted, as indicated, by the Boards of Directors of the insurance companies.

In Witness Whereof, the CNA Companies have caused these presents to be signed by their Vice President and their corporate seals to be hereto affixed on this 4th day of June, 2022.



Continental Casualty Company
National Fire Insurance Company of Hartford
American Casualty Company of Reading, Pennsylvania
Paul T. Bruflat
Paul T. Bruflat Vice President

State of South Dakota, County of Minnehaha, ss:

On this 4th day of June, 2022, before me personally came Paul T. Bruflat to me known, who, being by me duly sworn, did depose and say: that he resides in the City of Sioux Falls, State of South Dakota; that he is a Vice President of Continental Casualty Company, an Illinois insurance company, National Fire Insurance Company of Hartford, an Illinois insurance company, and American Casualty Company of Reading, Pennsylvania, a Pennsylvania insurance company described in and which executed the above instrument; that he knows the seals of said insurance companies; that the seals affixed to the said instrument are such corporate seals; that they were so affixed pursuant to authority given by the Boards of Directors of said insurance companies and that he signed his name thereto pursuant to like authority, and acknowledges same to be the act and deed of said insurance companies.



My Commission Expires March 2, 2026

M. Bent
M. Bent Notary Public

CERTIFICATE

I, D. Johnson, Assistant Secretary of Continental Casualty Company, an Illinois insurance company, National Fire Insurance Company of Hartford, an Illinois insurance company, and American Casualty Company of Reading, Pennsylvania, a Pennsylvania insurance company do hereby certify that the Power of Attorney herein above set forth is still in force, and further certify that the By-Law and Resolution of the Board of Directors of the insurance companies printed on the reverse hereof is still in force. In testimony whereof I have hereunto subscribed my name and affixed the seal of the said insurance companies this 25th day of October, 2023.



Continental Casualty Company
National Fire Insurance Company of Hartford
American Casualty Company of Reading, Pennsylvania
D. Johnson
D. Johnson Assistant Secretary

SECTION IX
COMPLIANCE AFFIDAVIT

I, David J. Rock, (Print Name) being first duly sworn on oath depose and state:

1. I am the (title) President of the Proposing Firm and am authorized to make the statements contained in this affidavit on behalf of the firm;
2. I have examined and carefully prepared this Bid based on the request and have verified the facts contained in the Bid in detail before submitting it;
3. The Proposing Firm is organized as indicated above on the form entitled "Organization of Proposing Firm."
4. I authorize the Village of Oak Park to verify the Firm's business references and credit at its option;
5. Neither the Proposing Firm nor its affiliates¹ are barred from proposing on this project as a result of a violation of 720 ILCS 5/33E-3 or 33E-4 relating to Bid rigging and Bid rotating, or Section 2-6-12 of the Oak Park Village Code relating to "Proposing Requirements".
6. The Proposing Firm has the M/W/DBE status indicated below on the form entitled "EEO Report."
7. Neither the Proposing Firm nor its affiliates is barred from agreementing with the Village of Oak Park because of any delinquency in the payment of any debt or tax owed to the Village except for those taxes which the Proposing Firm is contesting, in accordance with the procedures established by the appropriate revenue act, liability for the tax or the amount of the tax. I understand that making a false statement regarding delinquency in taxes is a Class A Misdemeanor and, in addition, voids the agreement and allows the Village of Oak Park to recover all amounts paid to the Proposing Firm under the agreement in civil action.
8. I am familiar with Section 13-3-2 through 13-3-4 of the Oak Park Village Code relating to Fair Employment Practices and understand the contents thereof; and state that the Proposing Firm is an "Equal Opportunity Employer" as defined by Section 2000(E) of Chapter 21, Title 42 of the United States Code Annotated and Federal Executive Orders #11246 and #11375 which are incorporated herein by reference. **Also complete the attached EEO Report or Submit an EEO-1.**
9. I certify that the Contractor is in compliance with the Drug Free Workplace Act, 41 U.S.C.A, 702

Signature: , President

Name and address of Business: IHC Construction Companies, LLC-385 Airport Rd., Suite 100 Elgin, IL 60123

Telephone 847-742-1516 E-Mail utility@ihcconstruction.com

Subscribed to and sworn before me this 25th day of October, 2019. 2023



Notary Public
Dayna Page Boekenhauer

- Notary Public Seal -

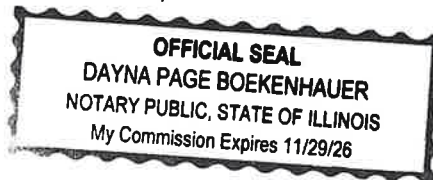

¹ Affiliates means: (i) any subsidiary or parent of the agreementing business entity, (ii) any member of the same unitary business group; (iii) any person with any ownership interest or distributive share of the agreementing business entity in excess of 7.5%; (iv) any entity owned or controlled by an executive employee, his or her spouse or minor children of the agreementing business entity.

SECTION X
M/W/DBE STATUS AND EEO REPORT

Failure to respond truthfully to any questions on this form, failure to complete the form or failure to cooperate fully with further inquiry by the Village of Oak Park will result in disqualification of this Bid. For assistance in completing this form, contact the Department of Public Works at 708-358-5700.

1. Contractor Name: IHC Construction Companies, LLC

2. Check here if your firm is:

- Minority Business Enterprise (MBE) (A firm that is at least 51% owned, managed and controlled by a Minority.)
- Women's Business Enterprise (WBE) (A firm that is at least 51% owned, managed and controlled by a Woman.)
- Owned by a person with a disability (DBE) (A firm that is at least 51% owned by a person with a disability)
- None of the above

[Submit copies of any W/W/DBE certifications]

3. What is the size of the firm's current stable work force?

171 Number of full-time employees

0 Number of part-time employees

4. Similar information will be requested of all subcontractors working on this agreement. Forms will be furnished to the lowest responsible Contractor with the notice of agreement award, and these forms must be completed and submitted to the Village before the execution of the agreement by the Village.

Signature:  _____
David J. Rock, President

Date: 10/25/2023

EEO REPORT

Please fill out this form completely. Failure to respond truthfully to any questions on this form, or failure to cooperate fully with further inquiry by the Village of Oak Park will result in disqualification of this Bid. An incomplete form will disqualify your Bid. For assistance in completing this form, contact the Purchasing Department at 708-358-5473.

An EEO-1 Report may be submitted in lieu of this report.

Contractor Name IHC Construction Companies LLC

Total Employees 171

Job Categories	Total Employees	Total Males	Total Females	Males				Females				Total Minorities
				Black	Hispanic	American Indian & Alaskan Native	Asian & Pacific Islander	Black	Hispanic	American Indian & Alaskan Native	Asian & Pacific Islander	
Officials & Managers	27	23	4		1							1
Professionals	32	24	8	1	2						1	4
Technicians	0											
Sales Workers	0											
Office & Clerical	11	3	8						3			3
Semi-Skilled	1	1										
Laborers	97	93	4	2	20				3			25
Service Workers	3	3										
TOTAL	171	147	24	3	23				6		1	33
Management Trainees												
Apprentices	5	4	1		2							

This completed and notarized report must accompany your Bid. It should be attached to your Affidavit of Compliance. Failure to include it with your Bid will be disqualify you from consideration.

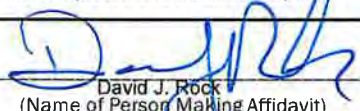
 being first duly sworn, deposes and says that he/she is the President
 (Name of Person Making Affidavit) (Title or Officer)
 of IHC Construction Companies LLC and that the above EEO Report information is true and accurate and is submitted with the intent that it

be relied upon. Subscribed and sworn to before me this 25th day of October, 2023

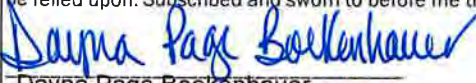
 Dayna Page Boekenhauer
 (Signature) 11/29/2023
 (Date)



SECTION XI
NO BID EXPLANATION

If your firm does not wish to propose on the attached specifications, the Village of Oak Park would be interested in any explanation or comment you may have as to what prevented your firm from submitting a Bid.

Bid Name: **Project No. 24-102; Village of Oak Park 2024 Water Service Line Replacement Program**

Comments:

Signed: _____

Phone: _____



10/26/2023

James E. Eggen, P.E.
Village of Oak Park
2024 Water Service Line Replacement Program
Bid Number: 24-102

Illinois Plumbing License #: Fellows Bros. Mechanical, Inc- 055-028260

Sincerely,

A handwritten signature in black ink, appearing to read 'L. Creadon', with a long, sweeping horizontal stroke extending to the right.

Lawrence C. Creadon
Director of Utility Operations

Corporate Office: 385 Airport Road, Suite 100, Elgin, IL 60123 • Phone: 847-742-1516 • Fax: 847-742-6610
Utility Division Office/Warehouse & Repair and Fabrication Shop/Yard: 1260 Bell Court, Pingree Grove, IL 60140 • Fax: 847-289-3650
Southeast Regional Office: 2700 Delk Road SE Suite 210, Marietta, GA 30067 • Phone: 404-497-7619 • Fax: 404-585-5085

www.ihcconstruction.com
ESTABLISHED 1906

SECTION I
REQUEST FOR BIDS
INSTRUCTIONS AND SPECIFICATIONS FOR:

Village of Oak Park
2024 Water Service Line Replacement Program
Bid Number: 24-102
Issuance Date: 10/4/2023

The Village of Oak Park will receive Bids from qualified contractors to preform water service replacements during the calendar year 2024 pursuant to this Request for Bids. This Bid covers the replacement of the water service on the public & private sides at various locations within the Village of Oak Park. Sealed Bids will be accepted at the Public Works Center, 201 South Blvd., Oak Park, IL 60302 Monday through Friday, 7:30 a.m. to 4:00 p.m. local time until **2:00 p.m. on Wednesday, October 25, 2023**. Bids will be reviewed and the results of the review will be presented to the Village Board of Trustees of the Village of Oak Park.

Specifications and bid forms may be obtained at <http://www.oak-park.us/bid> or at the Public Works Center at the address listed above.

The Village Board of Trustees reserves the right to accept or reject any and all bids or to waive technicalities, or to accept any item of any bid. Information is available from the Water & Sewer Superintendent, Michael Bills at 708-358-5700 or mbills@oak-park.us.

Do not detach any portion of this document. Upon formal award to the successful Bidder, a written agreement will be executed for the Project in substantially the form attached.

Submission of Bids

The Bid shall be submitted on the Bid form included herewith. The Bid shall be submitted in a **sealed** envelope marked "**BID: 24-102, 2024 Water Service Line Replacement Program**", shall bear the return address of the bidder, and shall be addressed as follows:

TO: Michael Bills, Water & Sewer Superintendent
Department of Public Works
201 South Blvd.
Oak Park, IL 60302

In responding to this Request for Bids the official logo of the Village of Oak Park is not to be used in any form. Use of the Village logo is strictly prohibited by law and such use could subject the proposer to disqualification.

BID FOR:
Village of Oak Park
2024 Water Service Line Replacement Program
SECTION II
BID INSTRUCTIONS, TERMS AND CONDITIONS

Preparation and Submission of Bid:

All Bids must be delivered to the Public Works Center by the specific time indicated on the cover page. Bids arriving after the specified time will not be accepted. Mailed bids that are received by the Village after the specified hour will not be accepted regardless of the post-marked time on the envelope. Bids must be signed by an officer of the company who is authorized to enter into agreements on behalf of the company. Bids shall be sealed in an envelope and marked as stated on the cover page.

Bid Bond

The Bidder shall provide a Bid Bond in the amount of ten percent (10%) of the total bid price. The attached form in Section VIII may be filled out or the contractor may provide cash or a certified check in the amount specified. The Bid bonds, cash, or checks will be returned once the selected contractor has entered into an agreement for this work and provided the Contract bond in an amount described herewith.

Contract Term

The initial contract term shall be from the date of award to December 31, 2024. The Village has the right to renew the contract on an annual basis for two (2) optional one-year terms (January 1 to December 31).

Contract Renewal

The Village will have the right to renew the contract for two (2) additional one (1) year terms with all terms and conditions, other than price, remaining the same. The Village will allow the Bidder to increase or decrease the contract price for each annual renewal.

Upon written request from the Bidder, on or before October 20 of each year of the Agreement, the cost of the services provided under the Agreement may be adjusted as follows:

The contractor shall submit a request for adjustment to the Village based upon the average of the published monthly Index (as defined below) for the period October through September for the previous year. The Index shall be the United States Department of Labor, Bureau of Labor Chicago Statistics, Revised Consumer Price Index for all Urban Wage Earners for Chicago-Naperville-Elgin, IL-IN-WI (all items, 1982-84 = 100).

Notwithstanding anything contained in this Request for Proposals to the contrary, an annual adjustment shall not be greater than five percent (5.0%) of the previous year's cost for services provided under this Agreement in any year.

Any applicable adjustment shall take effect on January 1st.

Notice to Proceed

Work shall begin within fourteen (14) days from the **Notice to Proceed** from the Water & Sewer Superintendent, Michael Bills, as locations are assigned. All work shall be completed in accordance with the detailed specifications set forth herein this document.

Recertification

If the Village renews the contract for an additional one year term, the Bidder will provide the Village with a renewed certification in the form in Section V indicating that it continues to be eligible to contract with units of local government. If a contractor or subcontractor is not able to certify that it continues to meet all requirements, it shall provide a detailed explanation of the circumstances leading to the change in certification status.

Award of Agreement

The Agreement will be awarded in whole or in part to the responsible Bidder or Bidders whose bids, conforming to the request for bids, will be most advantageous to the Village; price and other factors considered.

Costs of Preparation

The Village will not be responsible for any expenses incurred in preparing and submitting a Bid or entering into the applicable Agreement.

Taxes not Applicable

The Village of Oak Park as an Illinois municipality pays neither Illinois Sales Tax nor Federal Excise Tax. Contractors should exclude these taxes from their prices.

Withdrawal of Bids:

Any Contractor may withdraw its Bid at any time prior to the time specified in the advertisement as the closing time for the receipt of Bids, by signing a request therefore. No Contractor may withdraw or cancel its Bid for a period of sixty (60) calendar days after the advertised closing time for the receipt of Bids. The successful Contractor may not withdraw or cancel its Bid after having been notified that the Bid was accepted by the Village Board of Trustees.

Investigation of Contractors

The Village will make such investigations as are necessary to determine the ability of the Contractor to fulfill Bid requirements. If requested, the Contractor should be prepared to present evidence to the Village of Oak Park of ability and possession of necessary facilities and financial resources to comply with the terms of the attached specifications and Bids. In addition, the Contractor shall furnish the Village with any information the Village may request, and shall be prepared to show completed work of a similar nature to that included in its Bid. The Village reserves the right to visit and inspect the premises and operation of any Contractor.

Rejection of Contractor

The Village will reject any Bid from any person, firm or corporation that appears to be in default or arrears on any debt, agreement or the payment of any taxes. The Village will reject any Bid from a Contractor that failed to satisfactorily complete work for the Village under any previous agreement.

Conditions

Contractors are advised to become familiar with all conditions, instructions and specifications governing the work. Contractors shall be presumed to have a familiarity with this category of work. Work site, conditions and scope of the work before submitting a Bid.

Compliance with Applicable Laws

The Bidder will strictly comply with all ordinances of the Village of Oak Park and Village Code and laws of the State of Illinois.

Governing Law

All agreements entered into by the Village of Oak Park are governed by the laws of the State of Illinois without regard to conflicts of law. Any action brought to enforce an agreement with the Village of Oak Park must be brought in the state and federal courts located in Cook County, Illinois.

Subletting of Agreement

No agreement awarded by the Village of Oak Park shall be assigned or any part sub-agreement without the written consent of the Village of Oak Park or as noted in the Contractor's Bid. In no case shall such consent relieve the Contractor from its obligations or change the terms of the Agreement.

Interpretation of Agreement Documents:

Any Contractor with a question about this Bid may request an interpretation thereof from the Village no later than 8:00 A.M. on Friday, October 14, 2023. If the Village changes the Bid, either by clarifying it or by changing the specifications, the Village will issue a written addendum, and will post the Addenda on the Village website no later than 1:00 P.M. on Tuesday, October 18, 2023. All bidders will be responsible to check for any addenda. The Village will not assume responsibility for receipt of such addenda. In all cases, it will be the Contractor's responsibility to obtain all addenda issued. Contractors will provide written acknowledgment of receipt of each addendum issued with the Bid submission on the sealed bid envelope.

Minority Business and Women Business Enterprise Requirements

The Village of Oak Park, in an effort to reaffirm its policy of non-discrimination, encourages the efforts of Contractors and subcontractors to take affirmative action in providing for Equal Employment Opportunity without regard to race, religion, creed, color, sex, national origin, age, handicap unrelated to ability to perform the job or protected veteran's status.

Licenses

The Contractor shall be responsible for becoming a licensed Contractor in the Village. It is also understood that all plumbing work on this contract will be completed by a Licensed Plumbing Contractor in the State of Illinois.

Agreement

The selected bidder shall enter into an Agreement with the Village to complete the Project in a form substantially similar to the Agreement attached hereto. The Agreement shall be executed by the Contractor and returned, together with the Contract Bond within ten (10) calendar days after the Agreement has been mailed to the Contractor. The Contractor shall execute three copies of the Agreement. One fully executed copy will be returned to the Contractor. See Section XIII for a sample copy of the agreement.

Contract Bond

The successful bidder shall, within ten (10) calendar days after award of the bid, furnish a Contract Bond in the amount of fifty thousand dollars (\$50,000.00) for the contract awarded. The bond shall insure faithful performance of the work, and the payment for materials, labor and of the subcontractors. The bond shall be with a surety or sureties with a rating of "A" or better by A.M. Best and Company and such sureties shall be approved by the Village. Bonds in the form of certified or cashier's check shall be made payable to the Village of Oak Park, Illinois. The Contract Bond shall be furnished in the same number of copies as the number of copies of the Agreement to be executed. See section XII for a sample copy of the Contract Bond.

Fees and Cost

In the event any action is brought to enforce any agreement entered into by the Village of Oak Park, or to collect any unpaid amount from the Village of Oak Park, each party bears the responsibility of paying its own attorneys' fees and costs.

Dispute Resolution

The Village of Oak Park does not agree to mandatory arbitration of any dispute.

III GENERAL SPECIFICATIONS

Scope of Work

The Village is seeking Bids from qualified contractors for the replacement of lead water service lines from the water main to the curb stop (Public Side) and from the curb stop to the inside the residence as described herewith. The locations and sizes of service line are estimated for bidding purposes.

Responsibility of Contractor

The selected contractor shall furnish all labor, supervision, tools, equipment, materials and supplies, and other means necessary for performing and completing the work, including debris hauling, and shall obtain and pay for any required permits.

Extent of Services

This contract shall cover work as assigned by the Village for lead service line replacement where Village staff is unable to complete the work

Detail Specifications

1. Location of the Improvements

The location of the work is known as: PUBLIC RIGHT-OF-WAY and specific PRIVATE PROPERTIES within the Village of Oak Park, Illinois. Specific locations will be assigned after award of this contract.

2. Description of the Improvements

The Village of Oak Park has developed a lead water service line replacement policy that will replace the Public side of a one inch service at no cost to a residential property if the customer replaces their side first. The purpose of the work is to eliminate a lead service, increase size for added demand and/or repair a leaking service line.

The improvements under this contract shall include installing a new continuous water service line on the Public side (main to curb stop) of the water service. While the majority of the locations will have 1" services, it is anticipated that 1-1/2" and 2" water services will be encountered. All water services shall be new Type-K copper. This work shall include installation of a new corporation stop, curb stop and service box furnished by the Village. The installation of the curb stop will include connecting to the private side of the service line, as provided by the customer's plumber.

A second scenario under this contract shall include installing a new continuous water service line both on the Public & Private sides(from main all the way into residence) While the majority of the locations will have 1" services, it is anticipated that 1-1/2" and 2" water services will be encountered. All water services shall be new Type-K copper. This work shall include installation of a new corporation stop, curb stop, service box, new meter setting including full-port ball valves before and

after the meter with a boiler drain valve after the meter. A new water meter is optional to the homeowner and if selected, will be delivered to the jobsite. New meter connectors will be furnished, if necessary, by the Village. All brass and tapping sleeve will be supplied by Village.

It is the intent of this contract that the excavation for the new water main tap will be located next to the existing tap to allow disconnection of the existing tap. If a second excavation is required, this work shall be approved prior to commencing work. All new taps of the water main shall be scheduled with and performed by Village staff.

It is anticipated that the work under this contract will supplement and assist work performed by Village staff. As a part of the assistance to Village staff, the Village may call upon the contractor to directional drill service lines provided by the Village. The scope of this service is described in the specifications.

It is the intent of this contract that the installation of the new water service line will be completed by boring or directional drilling. Any deviations from this construction method shall require Village of Oak Park approval prior to commencing the work.

3. Project Schedule

This Contract will be for on-call work to be completed in 2024. The contractor shall complete the work within 10 calendar days upon notification by the Village. If Contractor declines the work or does not respond, the Village will contact the next lowest bidder. It will not be acceptable to delay completion of work in order to group or bundle work together.

Project Timeline

Project Advertising	Wednesday, October 4, 2023
Deadline for Questions	Friday, October 14, 2023@ 8:00am
Deadline for Addendum	Tuesday, October 18, 2023@ 1:00pm
Bid Opening	Thursday, October 25, 2023@ 2:00pm
Contract Award	Monday, December 5, 2023
Notice of Award	Tuesday, TBD
Preconstruction Meeting	Thursday, TBD
Notice to Proceed	Monday, TBD

Any questions pertaining to the contract shall be submitted in writing to the contact person for this contract. Any major issues or clarifications shall be summarized and issued in an addendum form to be published on the Village website. No questions shall be accepted after 8:00 A.M. on Friday, October 14, 2023 with no addenda to be issued after 1:00 P.M. on Tuesday, October 21, 2023. It is the bidder's responsibility to check the Village website for any addenda related to this contract.

The contact person for this contract shall be Michael Bills, Water & Sewer Superintendent. Written questions shall be e-mailed to mbills@oak-park.us with 2024 WATER SERVICE LINE REPLACEMENT PROGRAM in the subject line.

4. Reporting

The Bidder is responsible for keeping the Village updated on its work on a weekly basis. The Bidder will be required to provide the Village via email or in person a weekly report identifying the date the work was completed at each site was completed during the week as well as the materials used at the site. These reports are due before the close of business each Friday. Village staff will be spot checking locations each week.

5. Property Damage

The Bidder shall take great care to avoid damaging adjacent property, including sidewalk, fencing, landscape borders and landscaping (trees, shrubs, turf, etc.). Bidder shall be held responsible for all damage to property including, but not limited to, existing landscaping including turf, planters, bicycle racks, litter containers, light and traffic signal poles, parking meters, fire hydrants, curbs, vehicles, buildings and structures, etc. All damage will be the responsibility of the Bidder to repair to its original condition and to the satisfaction of the Village.

6. Idling of Equipment

The Department of Public Works has a “No Idling” policy. A copy of the policy is available from the Department of Public Works if needed. The bidder is expected to adhere to this policy as they are an extension of the Public Works Department staff.

7. Project Inspection

Upon Request the contractor must provide the location of crews working within the village. The Water & Sewer Project Manager or his representative will periodically inspect the work and will always be available should any problems arise. The Water & Sewer Supervisor or Superintendent can be contacted at 708-358-5700.

8. Obstruction of Streets and Rights-of-Way

The bidder shall arrange to keep sidewalks open for traffic when possible, and to block portions of the streets only when deemed necessary to protect private property.

The bidder shall remove all surplus materials and debris from the streets as the work progresses so that the public may have the use of the streets a maximum amount of time. Bidder is to erect appropriate warning signs and furnish adequate barricades that identify the work zone for the motoring public and pedestrians.

9. Accident Prevention

The bidder shall exercise every precaution at all times for the protection of the persons and properties. The safety provisions of all applicable laws and

ordinances shall be strictly observed. Any practice obviously hazardous in the opinion of the Water & Sewer Superintendent or authorized representative shall be immediately discontinued by the bidder upon their receipt of instructions from the Water & Sewer Superintendent, or authorized representative, to discontinue such practice.

The bidder shall abide by all applicable laws, standards, and regulations that apply to the completion of the work, including EPA and OSHA safety standards and regulations.

10. Motorized Equipment

Under no circumstances shall any motorized equipment be permitted to be driven on the private property or driveways without prior authorization from the resident and the Water & Sewer Superintendent while performing work under the provisions of this contract. Plywood or other support or protection must be placed on the parkway and/or private property prior to operating or parking vehicles or equipment on or over such property or other support or protection must be placed on the private property prior to operating or parking vehicles or equipment on or over private property.

11. Parking

No off-street parking for equipment shall be provided for by the Village of Oak Park on any of the Village's public properties except as may be designated by the Water & Sewer Supervisor or Superintendent.

12. Traffic Control Plan

Bidder's item of work shall include furnishing, installing, maintaining, replacing, relocating and removing all traffic control devices used for the purpose of regulating, warning or directing traffic during the water service line replacement.

Traffic control shall be in accordance with the applicable sections of the Standard Specifications for Road and Bridge Construction, the applicable guidelines contained in the Illinois Manual on Uniform Traffic Control Devices for Streets and Highways, these Special Provisions, and any special details and Highway Standards contained herein and in the plans.

The governing factor in the execution and staging of work for their contract is to provide the motoring public with the safest possible travel conditions near the work zone. The bidder shall arrange their operations to keep the closing of any traffic lane(s) of the roadway to a minimum.

13. Pedestrian Traffic Control

While the work under this contract is taking place, the bidder shall block off the sidewalk to pedestrian traffic immediately adjacent to the work site if there is a reasonable concern of harm to pedestrians.

Licenses and Permits

The Contractor shall be responsible for becoming a Licensed Plumbing Contractor with the Village of Oak Park. The Village will issue any necessary permits for this work at no fee.

Alterations, Omissions and Extra Work

The Village of Oak Park reserves the right to increase or decrease the quantity of any item or portion of the work, or to omit portions of the work as may be deemed necessary.

Method of Payment

The Village of Oak Park will pay monthly, all undisputed of invoices within 30 days of approval as provided in the Local Government Prompt Payment Act, 50 ILCS505/4. The maximum interest rate for any payment not made within 30 days of approval is 1%. Invoicing is to be submitted in accordance to the schedule of prices per project location. The work per location shall be billed once work at the location is complete.

Change Orders

Changes in the Work may be agreed to after execution of the Agreement, and without invalidating the Agreement, if the Change Order is in writing and signed. Any changes to the scope of work which result in an increase in the agreement price will be subject to an agreement addendum which must be signed by both parties. Any such Change Order will be prepared by the Village. The Contractor may only proceed with the Change upon receipt of the written Change Order signed by the Village.

Emergency Changes: Contractor may perform work not included in the Scope of Work if necessary to remedy a condition that poses an immediate threat to persons or property. Work of this nature shall be carried out only to the extent of bringing the condition under control. The Village shall be notified immediately. A Change Order will then be negotiated and executed for the work performed, and for work remaining, if any.

Minor Changes (Field Orders): The Village may verbally authorize minor changes in the Scope of Work in order to prevent a delay in the progression of the Work. These field orders may not involve a change in the agreement price or be inconsistent with the Scope of Work.

Changes Due to Unknown Conditions: The Contractor is not responsible for Changes in the Work that are due to conditions that were not reasonably observable or conditions that have changed. In such cases, the Contractor shall notify the Village and a Change Order will be negotiated.

Any Change which results in a total agreement price in excess of \$10,000 must be approved by the Village of Oak Park Board of Trustees.

Correction of Work Prior To Final Payment

The Village has the right to stop work if the Contractor fails to carry out the work in a manner acceptable to the Village. If the Village deems the Contractor's work unacceptable, at the Village's election, the Contractor shall do one of the following:

1. Promptly repair or replace the defective work, without expense to the Village, including costs associated with repairing any damage to property caused by the replacement work; or;
2. If the Village deems it unacceptable to have the Contractor correct work which has been incorrectly done, a deduction from the agreement price shall be made based on the costs to the Village to have the work repaired. Such a deduction from the agreement price shall in no way affect the Village's other remedies or relieve the Contractor from responsibility for defects and related damage occurring as a result of defective or unacceptable work.

Bidder's Representative

The bidder shall have at all times a competent foreman or superintendent on the job that shall have full authority to act for the bidder, and to receive and execute orders from the Director of Public Works or appointed representative. Any instructions given to such superintendent or person executing work for the bidder shall be binding on the bidder as though given to him personally. Bidder's representative must be proficient in the use and interpretation of the English language.

Workers

The bidders shall employ competent laborers and shall replace, at the request of the Director of Public Works any incompetent, unfaithful, abusive or disorderly workers in their employ. Only workers expert in their respective branches of work shall be employed where special skill is required. Inappropriate behavior or examples of unproductive work effort will not be tolerated. The Village has the right to require a bidder's employee to be immediately removed from the work crew if the above behavior is exhibited.

Time of Work

Bidder shall only work on weekdays, (Monday through Friday), from 7:30 a.m. to 4:30 p.m. No work will be allowed outside the standard workhours, on weekends or on legal holidays as recognized by the Village of Oak Park, except as authorized by the Director of Public Works.

Dispute Resolution

All disputes, including collection disputes, shall be brought in the Circuit Court of Cook County, Illinois. This agreement shall be interpreted in accordance with the laws of the State of Illinois. In any dispute resolution process, each party shall bear its own costs, including attorney's fees. Any purported agreement between the parties that states terms contrary to this paragraph M will be deemed per se invalid.

Reporting Requirements

The following forms must be completed in their entirety, notarized and included as part of the Bid document. Failure to respond truthfully to any question on the list or failure to cooperate fully with further inquiry by the Village of Oak Park will result in disqualification of your Bid.

VILLAGE OF OAK PARK

2024 SUPPLEMENTAL SPECIAL PROVISIONS

The following Supplemental Special Provisions supplement the Village of Oak Park General Conditions and the State of Illinois “Standard Specifications for Road and Bridge Construction,” adopted January 1, 2017 and the latest edition of the “Manual on Uniform Traffic Control Device for Streets and Highways,” and the “Standard Specifications for Water and Sewer Main Construction in Illinois,” in effect on the date of invitation for bids. In case of conflict with any parts of said specifications, the said Supplemental Special Provisions shall take precedence and shall govern. The above-named publications shall hereinafter be referred to as the “Standard Specifications” which apply to and govern the construction of the ***2024 WATER SERVICE LINE REPLACEMENT PROGRAM.***

1. GENERAL

The Village has adopted a lead water service line replacement policy. The policy is as follows:

1. Lead Water Services Disturbed During Leak Repair: The Village conducts repairs to approximately 20 leaking lead water services annually. During the repair to the water service, the lead water service is disturbed. Therefore, full service line replacement (water main to meter) is required when lead water service lines are repaired. If a property owner does not allow the work to be performed on private property, a sign-off acknowledging the acceptance of a partial lead service replacement will be obtained, the public portion of the water service line will be replaced including a new main tap and new curb stop valve. Village staff will provide direction and material to connect to the existing service on the private side. If customer allows access then the whole lead service line will be replaced.
2. Lead Water Service Upgrade: Residential customers wanting to upgrade their water service for extra capacity and/or lead elimination will hire a contractor to replace the service line from the parkway to the meter, usually upgrading the size of pipe and the meter. If the property owner replaces the private portion, the Village will replace the public portion of the water service at no cost for a 1” service. Minimal charges would apply for 1-1/2” or 2” service lines. The customer would replace the private side of the service first, including excavation of the parkway. The Village requires the parkway excavation to be left open, with the site protected unless extenuating circumstances requires backfill.

The Village is seeking the services of a Contractor to complete water service line installation on an on-call basis. The general procedure will be as follows:

Review Project with Property Owner

After the Notice to Proceed is issued for the contract, the Village of Oak Park will provide any addresses and contact information for the property owners where work is pending. At that

time, the Village will also notify the owners of whom the successful bidder is. The Contractor and Village of Oak Park are then required to meet with the owner, if work is required on private property, to review the work at the subject location with the property owner. The property owner can withdraw from the program at this point. The contractor will then offer the Acceptance/Withdrawal Letter to the property owner. This letter will serve as the property owner's permission to allow the Village contractor(s) to work on private property.

Schedule and proceed with the work

Water service lines should be installed via directional drilling or boring to the maximum extent possible to minimize impacts to public and private property. If completing a whole service line replacement, the bore should be below the building foundation in such a manner as to allow a continuous type K copper tubing of the required diameter to be installed between the building and the curb stop. The new water service pipe shall extend at least 18 inches into the building before any fittings are installed. Work covered under this contract will generally fall under two scenarios:

Scenario #1: Lead Water Service Disturbed During Leak Repair or Meter Replacement

1. Village disturbs a lead water service during a leak repair or meter replacement. Village completes temporary repair.
2. Village leaves letter at door and also mails letter to property owner notifying them that they have a lead water service line and asking them to contact Village to verify interior lead service line (if leak repair), and discuss lead service line replacement program.
3. Village contacts the successful low bidder to schedule the work. Village provides contractor with property owner contact information.
4. If property owner agrees to have work completed on private property, Village & Contractor would coordinate with the customer. Offer the Acceptance/Withdrawal Letter to the property owner. This letter will serve as the property owner's permission to allow the Village contractor(s) to work on private property
5. If property owner does not agree to have work completed on private property, the Village Contractor will complete replacement of public portion of lead water service line from water main to b-box, including any necessary excavations in the parkway.

Scenario #2: Lead Water Service Upgrade by Owner

1. The Customer hires a contractor to upgrade the lead water service for additional capacity and/or lead elimination.
2. Public Works will be notified during the permitting process of the owner's intent to upgrade the water service. During permit review, the Village will determine any fees and/or conditions on the Customer's contractor to complete the work.
3. If property owner chooses to replace the private portion of their lead water service, the Village will replace the public portion of the lead water service.
4. The Customer/Owner's contractor is required to provide 72-hour notice to Public Works. At select locations, the Village will contact the successful low bidder to schedule completion of the work on the public side. Village provides contractor with owner contact information.

5. Village of Oak Park contacts property owner to discuss project scheduling and confirm participation in program.

Contractor shall be responsible for locating water and sewer utilities on private property per the contract terms. **Sewer service shall be inspected and located to avoid conflicts with the water service installation.**

The interior meter setting needs to be installed according to the Service Line Installation Detail included with these documents. Polyethylene encasement of the copper tube when in contact with concrete shall be to wrap that portion of the pipe with electrical tape or other approved method to prevent direct contact of the copper and concrete.

Copper service tubing shall terminate at a MIP threaded connector or a flared fitting. Full port ball valves shall be used before and after the meter setting with a drain valve located after the meter. Connection to the existing plumbing shall be with a dielectric union adaptor if connecting to dissimilar material.

Any work necessary to complete the water service installation as described in these documents that does not have a pay item shall be considered incidental to the contract. The following list identifies examples of incidental items. This list shall not be considered a complete or exhaustive list.

- All removals including breaking basement slab, core drilling and/or saw cutting.
- Hand excavation and removal of spoil from inside building.
- Backfilling interior floor openings with granular material.
- Dust control inside buildings.
- Crimping or freezing of water services.
- Shrub and bush disposal.
- Traffic control and protection.
- Overnight protection of work areas.
- Testing of excavated materials.
- Disposal of CCDD materials.
- Sediment control.

Restoration

Final restoration of the parkway, concrete curb, concrete sidewalk and/or road surfaces will be completed by the Village.

Final installed water service route shall be shown on Water Service Installation Sketch to be provided by Contractor to Village for record keeping purposes. This sketch shall also identify detailed dimensions of restoration to be performed by the Contractor.

Work may need to be completed on Saturdays to accommodate residents. No additional compensation will be allowed for work completed on Saturdays.

Contractor will be responsible for all testing and proper disposal of spoils generated from this work. Removal of spoils classified as CCDD shall be considered incidental to the contract.

All interior site restoration, of concrete slabs will be completed by the contractor under this contract.

All improvements on private property will become the property of the homeowner.

The necessary removal of fences shall be replaced under the contract terms and will be considered incidental.

Any damage to the interior or exterior of the home caused by the contractor shall be repaired at no additional cost to the Village or the Homeowner. Interior restoration would be limited to replacement of walls if removed. Painting would not be included.

The existing tap and corporation stop shall not be disturbed. If a new tap is required it will be performed by the Village of Oak Park Water Department. Existing B-boxes and curb stops shall be reused. If the curb stop and B-box needs to be replaced, a new curb stop and B-box will be furnished by the Village.

Water & Sewer Separation requirements apply for water and sewer service lines. Horizontal and vertical separation of water service lines and sewer service lines shall be done in accordance with the latest edition of the "Standard Specification for Water and Sewer Construction in Illinois."

Any claims for additional work must be presented to the Village immediately. Failure of the contractor to notify the Village Inspector will be reason to deny any claims for extra work.

All work covered under this contract is subject to inspection by the Village of Oak Park Building Inspections Department as well as the Department of Public Works and Utilities. Plumbing inspections will be required. Permit fees will be waived but Contractor is responsible for obtaining a permit and scheduling the work with the Village of Oak Park.

Contractor shall provide sediment control devices for all storm inlet structures within or adjacent to project limits and shall keep all streets tidy and clean of debris. This shall be considered incidental to the contract.

2. TRENCH BACKFILL

This work shall conform to Section 208 of the "Standard Specifications". This item shall consist of furnishing, placing, compacting and transporting course aggregate gradation CA-6 or CA-7 for backfilling material for all trenches made within the roadway, driveways and as directed by the Engineer. Parkway Excavations shall be backfilled with granular material up to 6 inches below the surface with the remainder backfilled with suitable soil material. All compaction shall be not less than 85 percent optimum, modified proctor. The material shall

conform to Article 1004.5. This item also includes the disposal of the surplus excavated material which is replaced by trench backfill. Such disposal shall be made in accordance with Article 202.03 of the "Standard Specifications".

The Contractor shall maintain trenches flush with existing surfaces until permanent patches are installed or roadway excavation has begun. No additional compensation will be provided to the Contractor for trench maintenance.

Basis of Payment:

This work will be paid for at the contract unit price per cubic yard for TRENCH BACKFILL. Quantities incorporated into this item shall be measured by either Article 208.03(a) of the "Standard Specifications" or the Trench Backfill table published by the State of Illinois, Department of Transportation, Division of Highways, Bureau of Construction. See table in General Conditions.

3. PROJECT MANAGEMENT

Project Management shall include all supervision work associated with coordinating and performing the installation at a given property. A two-hour maximum allotment will be allowed for each property with a successful agreement form or one hour for a project refusal. This work will include contacting the owner, meeting with the property owner to layout the installation, **obtaining property owner signature on Village agreement form**, payment plan (if applicable), no participation form or sample refusal form, providing the Village with sketch of as-built installation, scheduling the work and any follow-up meetings to explain the installation. No additional compensation will be allowed for the management of the project.

Photographs or video shall be taken at each property prior to the start of construction work to document the pre-existing conditions.

Monthly invoices should provide a breakdown of items and cost per property. Costs associated with preparing this breakdown shall be incidental to the contract.

Project Management can only be billed on full service line replacement where contractor will be working on private property

Basis of Payment:

This work will be paid for as 1 or 2 Hours for each property at the contract unit price per hour for PROJECT MANAGEMENT. No additional compensation will be allowed.

4. UTILITY LOCATION – PRIVATE PROPERTY

This work shall include all labor, equipment and materials associated with locating the existing water and sewer services and private electric lines on private property. Where locates are not provided for the water service or sewer service, the Contractor shall complete locating services. Private electric lines for yard lamp posts or secondary structures for means of installing new service line.

Basis of Payment:

The work will be paid for at the contract unit price each for UTILITY LOCATION – PRIVATE PROPERTY.

5. WATER SERVICE LINE TYPE K – OPEN CUT, 1”, 1-1/2”, 2”

This work shall include furnishing and installing all materials required to lay water service piping according to Sections 41-2.12c and 41-2.13 of the “Standard Specifications for Water and Sewer Main Construction in Illinois 7th Edition.” Embedment up to one foot above the pipe and earthen backfill shall be included in the cost per lineal feet of water service line. The service pipe is to be continuous and have no intermediate unions. This item shall include type K copper tubing at a minimum size of 1” diameter.

All service lines shall have a minimum depth of 60”, unless otherwise approved by the Engineer. Service Lines shall be continuous unless approved by the Engineer with any buried joints made using flared connectors.

Basis of Payment:

The work will be paid for at the contract unit price per lineal foot for WATER SERVICE LINE TYPE K – OPEN CUT of the size specified.

6. WATER SERVICE LINE TYPE K – DIRECTIONAL DRILLING, 1”, 1-1/2”, 2”

This work shall include furnishing and installing all materials required to directionally drill water service piping according to Sections 41-2.12c and 41-2.13 of the “Standard Specifications for Water and Sewer Main Construction in Illinois 7th Edition.” Open cut excavation through roadways for long side water services will not be acceptable. Directional drilling shall be used where practicable to minimize damage to private property. The service pipe is to be continuous and have no intermediate joints. This item shall include all excavation necessary for approach and receiving pits. This item shall include providing type K copper tubing at a minimum size of 1” diameter.

All service lines shall have a minimum depth of 60”, unless otherwise approved by the Engineer.

Basis of Payment:

The work will be paid for at the contract unit price per lineal foot for WATER SERVICE LINE TYPE K – DIRECTIONAL DRILLING of the size specified.

7. EXCAVATION

This work shall include all labor, equipment and materials for the excavation, transportation and disposal of suitable materials and expose the water main or service line to complete the work item. Excavations in hard surfaces shall be saw cut prior to excavating. All excavations shall be neat and kept small as practical. Any holes to be left open overnight shall be protected with steel plates in roadway or ¾” plywood in parkways. All excavated Materials shall be removed from site at the end of the day.

SERVICE CONNECTION TO WATERMAIN EXCAVATION shall expose and clean 24” of the water main to be tapped. The hole shall be at least 4 ft. x 6 ft. and to a depth of 6 inches below the water main and be located next to the existing tap to be disconnected. Oversized holes shall be considered one excavation. Included.

WATER SERVICE DISCONNECTION EXCAVATION will be permitted at areas where the location of the service line is relocated away from the existing tap and a separate excavation is required. The depth of the excavation shall be to the top of the water main to allow the corporation valve to be closed. Saw cutting for this item will be incidental.

PARKWAY EXCAVATION will be required at locations where the upgraded water service has been backfilled in the parkway. This condition will be encountered where temporary connections to the lead service have been made and the area filled to protect the service from weather or other hazards.

Basis of Payment:

The work will be paid for at the contract unit price per each for SERVICE CONNECTION TO WATER MAIN EXCAVATION, WATER SERVICE DISCONNECTION EXCAVATION or PARKWAY EXCAVATION accordingly.

8. CRIMP/FREEZE WATER SERVICE

This work shall include all labor, equipment and materials required to excavate and crimp or freeze the existing water service in order to complete water disconnections and/or water service connection at locations approved by Engineer where both the curb stop and interior shut-off are broken or where the curb stop or corporation tap cannot be located. A new curb stop valve, furnished by the Village, would be installed on the service line to control the flow of water.

Basis of Payment:

The work shall be considered incidental to the contract.

9. WATER SERVICE CONNECTION ON PRIVATE PROPERTY

This item shall include furnishing and installing all materials required to connect to the existing water service on interior of home up to the isolation ball valve after the water meter in accordance with Service Line Installation Detail WSU-001 and the connection to existing plumbing.

For foundation wall entry, the Contractor shall core drill the existing foundation wall to allow for penetration by the 1" copper water service pipe. The Contractor shall install a Polyethylene or PVC sleeve in the foundation to protect the copper service pipe. The interior and exterior of the cored hole shall be completely sealed with hydraulic cement to prevent water infiltration. The Contractor shall exercise caution to prevent damaging the existing foundation. The Contractor shall be responsible for repairing any damage to the foundation caused by the coring operation. The Contractor shall be responsible for moving and restoring any items on the interior of the home that infringe upon the work.

For under footing basement floor entry, the Contractor shall break out a hole in the floor. The Contractor shall install a polyethylene or PVC sleeve in the concrete patch or polyethylene wrap on the copper tubing to protect the copper service pipe. The basement floor shall be repaired with compacted aggregate base and 4 inches of concrete. The water pipe shall be completely sealed with hydraulic cement to prevent water infiltration. The Contractor shall exercise caution to prevent damaging the existing slab. The Contractor shall be responsible for repairing any damage to the slab caused by the drilling and removal operation. The Contractor shall be responsible for moving and restoring any items on the interior of the home that infringe upon the work.

The Contractor is responsible for any modifications to the interior plumbing necessary to install new water service. New interior water shut-off valves (ball valves) shall be installed on either side of meter. If existing meter is determined to be in need of replacement, Contractor shall install a new meter provided by Village.

The Contractor shall be responsible for providing dust control and removing any debris generated by the work on the interior and exterior of the building and restore the area around the water service as nearly as practicable to its original condition.

This work shall also include abandoning the existing water service line in place. The existing plumbing shall be capped and/or plugged with hydraulic cement flush with the wall or slab.

Basis of Payment:

The work will be paid for at the contract unit price each for WATER SERVICE CONNECTION ON PRIVATE PROPERTY.

10. WATER METER RELOCATION

This work shall include all labor and materials required to relocate existing water meter to new water service entry point into home. Meter shall be located immediately upon entrance of the service pipe into the home approximately 3' off the ground. Meter shall be installed such that it is accessible for maintenance. Contractor to provide and install new shut-off valves (ball valve) on each side of the meter, drain connection between two shut-off valves, and #4 solid copper grounding wire between upstream and downstream with bronze ground clamps.

Basis of Payment:

This pay item is only applicable when new water service location is required as determined by the Village Engineer. The meter would typically be moved over 15' from the original location. The work will be paid for at the contract unit price each for WATER METER RELOCATION.

11. WATER SERVICE LINE TYPE L

This work shall include furnishing and installing all materials required to connect existing interior piping to new water service location. All fittings required to complete this work shall be considered incidental.

Basis of Payment:

The work will be paid for at the contract unit price per lineal foot for WATER SERVICE LINE TYPE L for the size specified as measured from the secondary shut off valve to the connection point of the existing plumbing in the nearest one-foot increments.

12. REMOVE AND REPLACE HOT WATER HEATER

This work shall include all labor, equipment and materials required to remove and replace the existing hot water heater (HWH) where it is blocking the existing water service entry point and/or water meter. This item will include draining the HWH, disconnecting the plumbing, gas supply and flue pipe and/or electric supply, temporarily moving and reinstalling the existing HWH.

Basis of Payment:

The work will be paid for at the contract unit price per each for REMOVE AND REPLACE HOT WATER HEATER.

13. HAND DIG EXCAVATION ALLOWANCE, 4 FT., 5 FT., 6 FT.

This item shall cover all additional cost associated with performing an excavation in an isolated area which permits only hand excavation. Additional labor for the removal of the excavated material and transporting of the fill materials shall be included with this item. This item shall include hand digging as a result of utility conflicts and/or digging and root pruning to protect trees.

Basis of Payment:

The item will be paid for as HAND DIG EXCAVATION ALLOWANCE for every occurrence of the depth specified. The Village shall be notified if hand digging is required prior to commencing this work. No additional compensation will be allowed for work covered under this item.

14. REMOVE AND REPLACE DRAIN TILES

This work shall include all labor, equipment and materials required to remove and replace existing 4" or 6" drainage tiles that are damaged or removed due to installation of the water service line. Construction shall extend on each side of the crossing until the perpendicular distance from the water main to the sewer is at least 1 foot. Constant O.D. mission couplings shall be used to connect new pipe to existing pipe. Contractor shall clean all drainage tiles which are disturbed and confirm positive drainage is maintained.

Basis of Payment:

The work will be paid for at the contract unit price per lineal foot for REMOVE AND REPLACE SEWER SERVICE LINES.

15. REMOVE AND REPLACE SEWER SERVICE LINES

This work shall include all labor, equipment and materials required to remove and replace existing 4" or 6" sanitary sewer service lines that are damaged or removed due to installation of the water service line. Where water and sewer separation requirements are not met, the service lateral or building service shall be replaced with ductile iron pipe or watermain quality PVC (C900). Construction shall extend on each side of the crossing until the perpendicular distance from the water main to the sewer is at least 10 feet. A minimum 18" vertical separation is required. Non-shear, shielded, constant O.D. missions shall be used to connect new pipe to existing pipe. Post repair sewer televising of any damaged sewer service lines shall be completed by the Contractor, incidental to this item, prior to acceptance of the work.

Basis of Payment:

The work will be paid for at the contract unit price per lineal foot for REMOVE AND REPLACE SEWER SERVICE LINES.

16. TRAFFIC CONTROL AND PROTECTION

This item shall include furnishing, installing, maintaining, relocating and removing all traffic control devices used for the purpose of regulating, warning or directing traffic during construction or maintenance of this improvement.

Traffic Control and Protection shall be provided as called for in the plans, these Special Provisions, applicable Highway Standards, applicable sections of the Standard Specifications or as directed by the Engineer.

The governing factor in the execution and staging of work for this project is to provide the motoring public with the safest possible travel conditions along the roadway through the construction zone. All traffic control devices used on the project shall conform to the plans, special provisions, traffic control standards, traffic specifications and the "Illinois Manual on Traffic Control Devices for Streets and Highways" and the "Traffic Control Devices Handbook". No modification of these requirements will be allowed without prior written approval of the Engineer.

The Contractor shall be responsible for proper location, installation and arrangement of all traffic control devices. Contractor shall upon request of Engineer provide a sketch of proposed traffic control devices to be installed. All traffic control devices shall remain in place until specific authorization and relocation or removal is received from the Engineer.

The Contractor shall ensure that all traffic control devices installed by him are operational 24 hours a day, including Sundays and holidays.

Basis of Payment:

This work will be considered incidental.

17. LANDSCAPE RESTORATION (Private Property)

This item shall include all materials, equipment, and labor, required to removed disturbed landscaped areas to allow placement of 6 inches of pulverized topsoil with seed and blanket. All work shall be performed in accordance with Section 211 of the Standard Specifications. Seeding shall be raked into the surface prior to placement of straw blanket. This item is only for private property and not parkway restoration.

Basis of Payment

This work shall be paid for at the contract unit price per square foot, for LANDSCAPE RESTORATION.

18. TESTING FOR CONTAMINATED MATERIAL: (Revised 1/1/13)

This item shall include all materials, equipment, and labor, required to test ALL excavated materials for environmental contaminants as dictated by Clean Construction or Demolition Debris (CCDD) Legislation (PA 96-1416) incidental to the contract. It is the Contractor's responsibility to create and maintain all testing documentation to be supplied upon request.

Basis of Payment

All testing required shall be incidental to the contract.

19. REMOVAL AND DISPOSAL OF CONTAMINATED MATERIAL:

This item shall include all materials, equipment, and labor, required to remove and dispose of any excavated material which tests positive for contamination in accordance with all IEPA regulations.

Basis of Payment

This work shall be paid for at the contract unit price per cubic yard, for REMOVAL AND DISPOSAL OF CONTAMINATED MATERIAL.

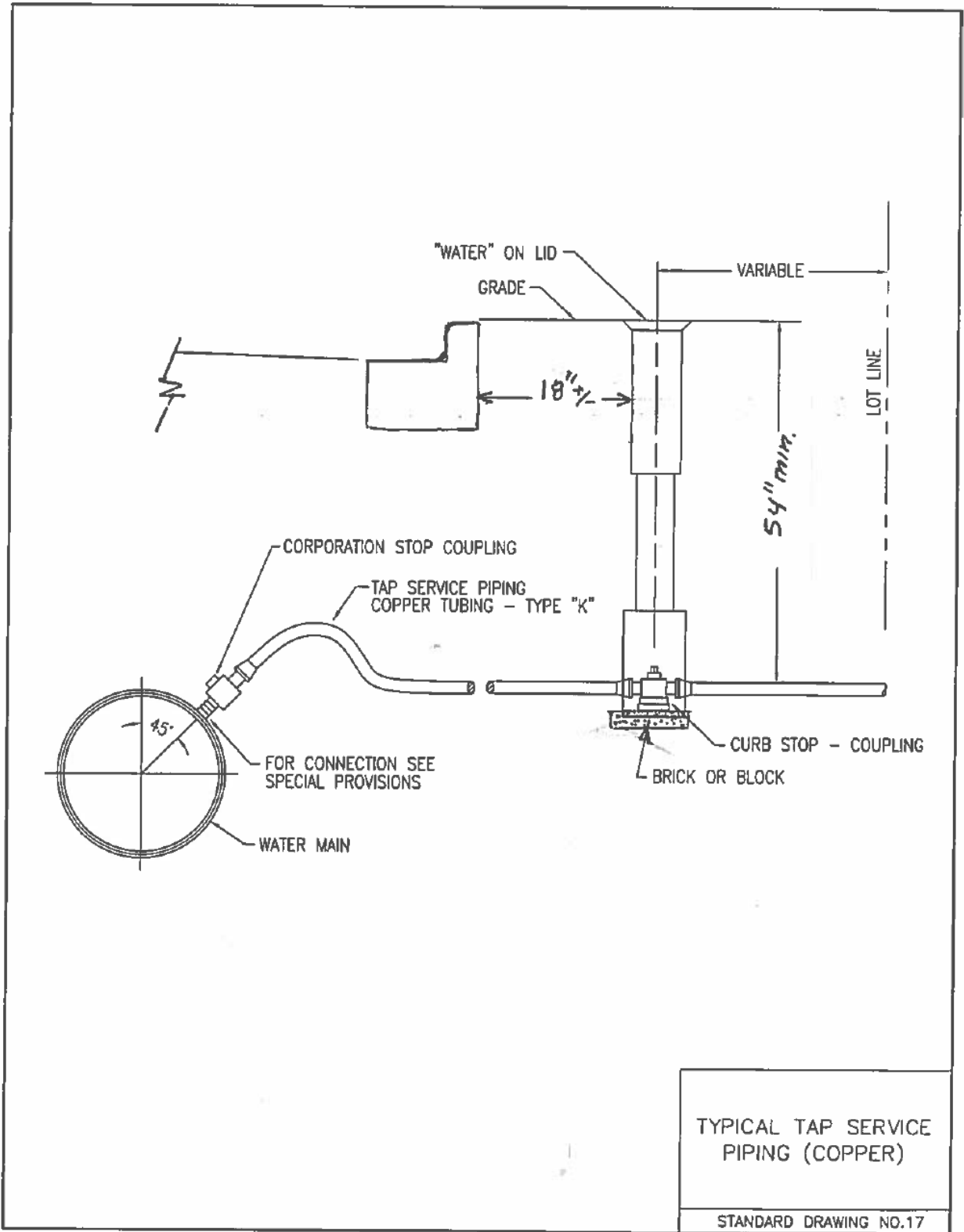

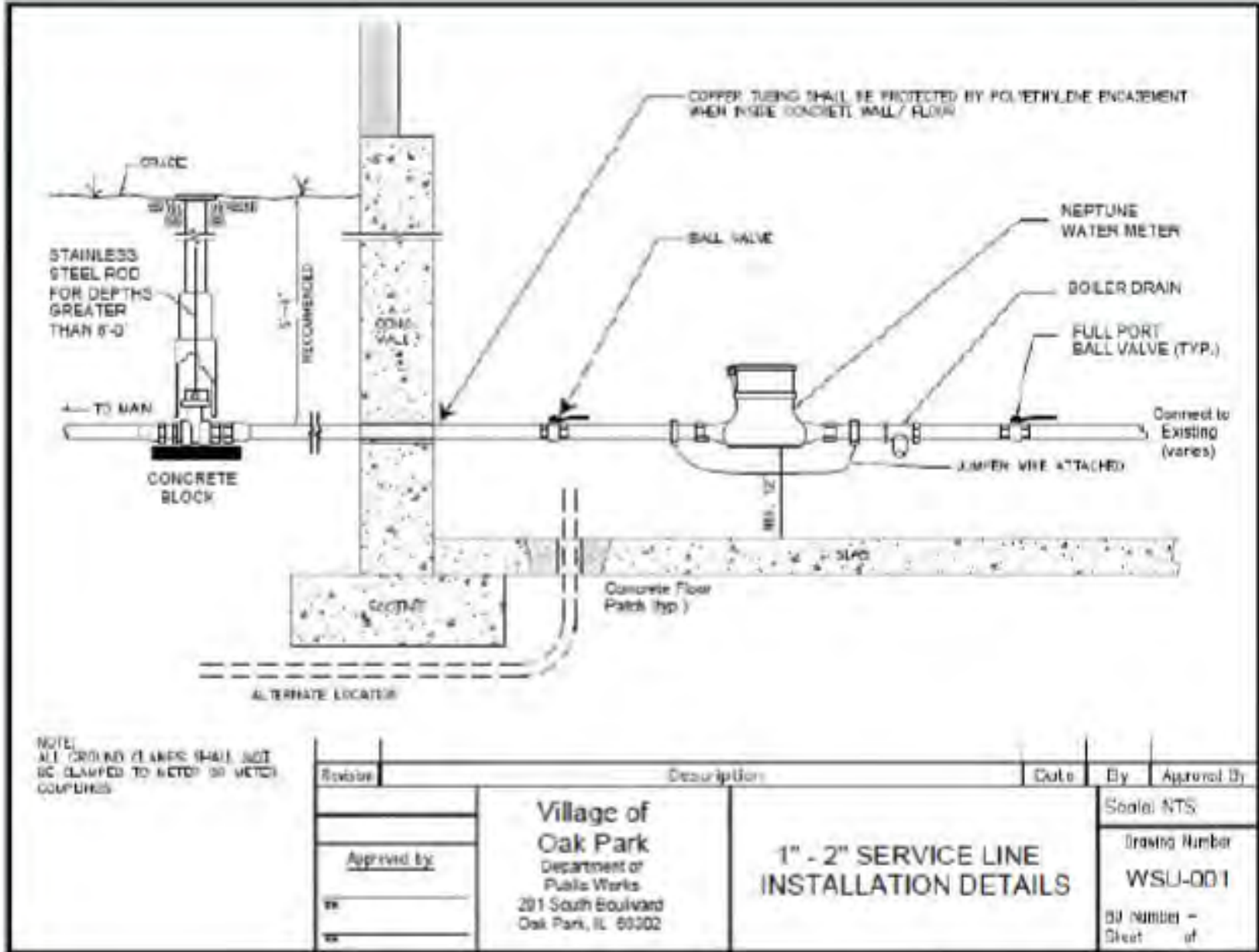

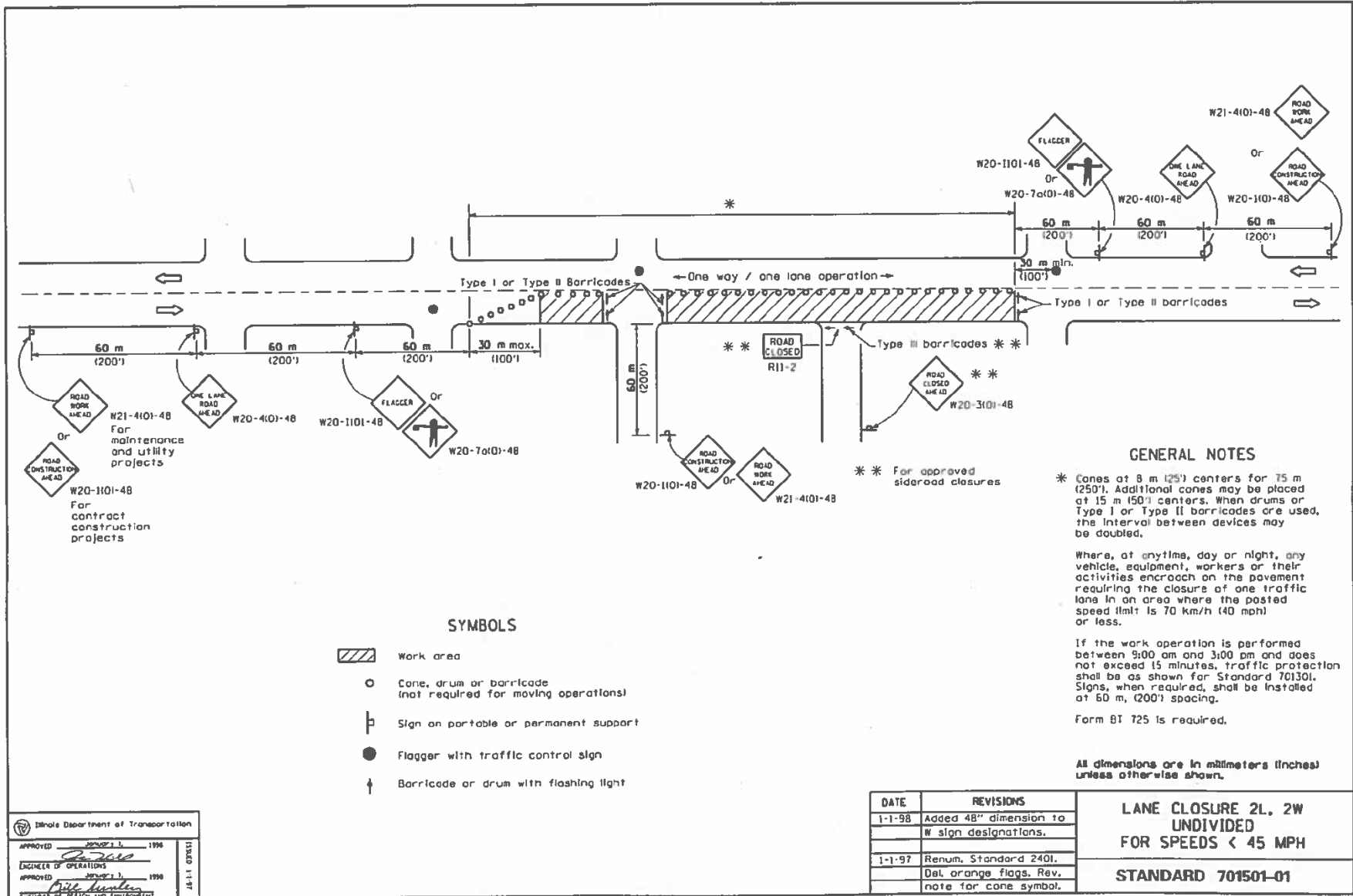

Notes:
When workers are present,
close 2 lanes as shown in
Standard 701501.

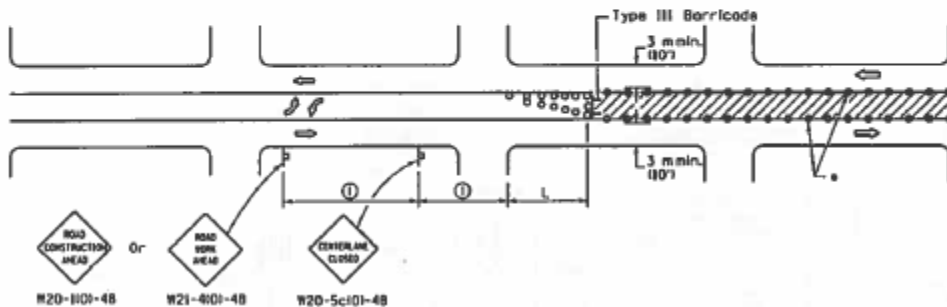

CASE I

Signs required for both directional

SIGN SPACING	
Posted Speed Sign Spacing	
55 (4)	150 m (500')
60-65 (4)	115 m (350')
65	90 m (290')

- ① = Refer to SIGN SPACING TABLE for distances.
- ② = Required for speeds > 70 km/h (40 mph).
- ③ = Required if work exceeds 164 m (500') or 1 block.
- ④ = For speeds exceeding 80 km/h (45 mph) contact the District Operations Office for approval of sign spacing.

SYMBOLS

- ↑ Arrow board
- ▨ Work area
- ⊕ Barricade or drum with steady burning omnidirectional light
- | Barricade or drum without flashing light
- Flagger with traffic control sign
- Cone, drum or barricade (Cones for daytime use only)
- ⊥ Sign on portable or permanent support

GENERAL NOTES

- Cones at 8 m (25') centers for 75 m (250'). Additional cones may be placed at 15 m (50') centers. When drums or type I or II barricades are used, the interval between devices may be doubled.

Where L is:

SPEED LIMIT FORMULAS

70 km/h (40 mph) or less: Metric $L = \frac{WS^2}{150}$ (English) $L = \frac{WS^2}{60}$

80 km/h (45 mph) or greater: $L = 0.65(WHS)$ $L = (WHS)$

W = Width of offset in meters (feet).

S = Road posted speed km/h (mph).

All dimensions are in millimeters (inches) unless otherwise shown.

Ministry Department of Transportation

APPROVED: *[Signature]* 2008

DESIGNER OF OPERATIONS: *[Signature]*

APPROVED: *[Signature]* 2008

STANDARD 701502 (REVISED)

DATE	REVISIONS
1-1-01	New Standard

URBAN LANE CLOSURE
2L, 2W WITH BIDIRECTIONAL
LEFT TURN LANE
 (Sheet 1 of 2)
STANDARD 701502

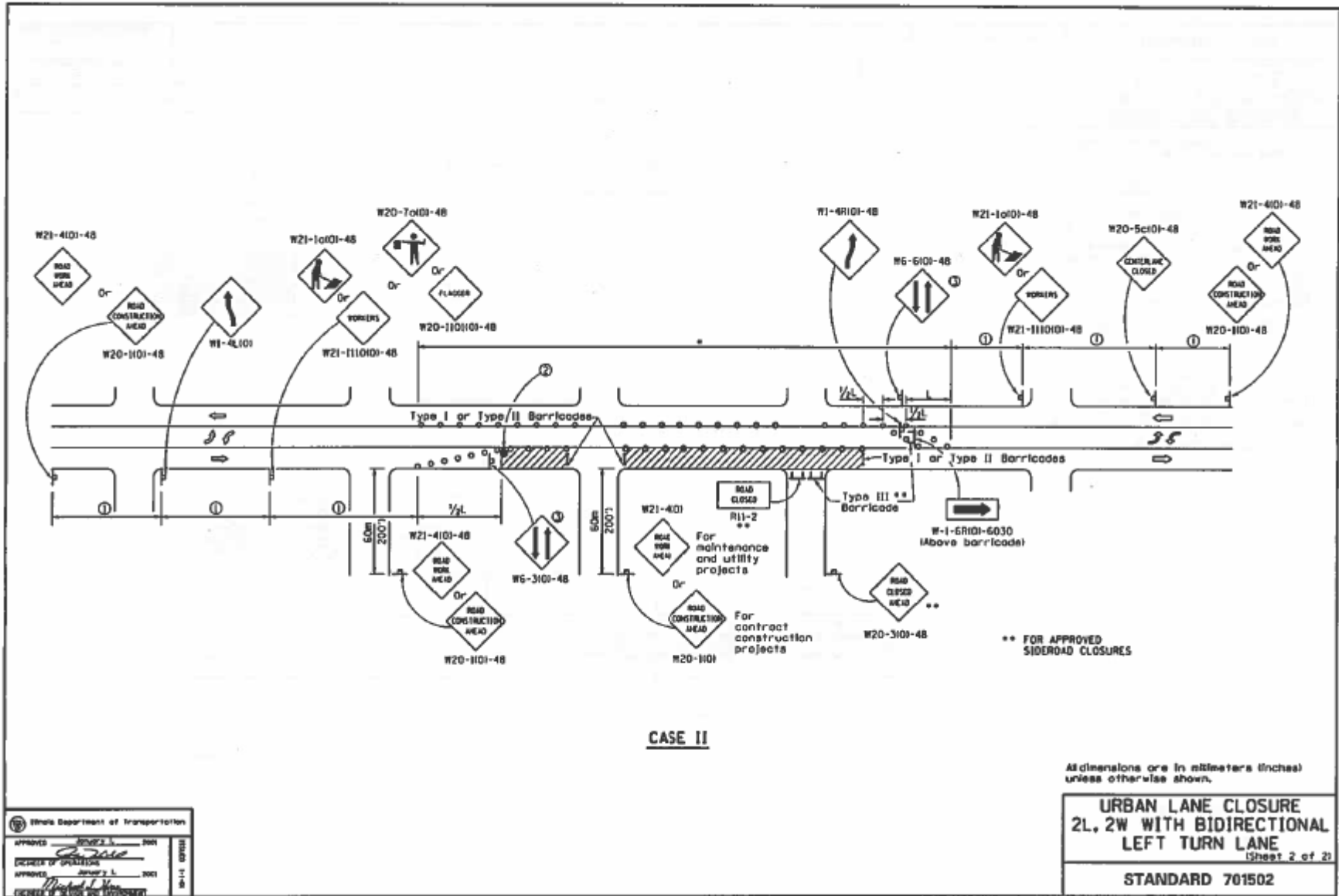

CASE II

All dimensions are in millimeters (inches) unless otherwise shown.

**URBAN LANE CLOSURE
2L, 2W WITH BIDIRECTIONAL
LEFT TURN LANE**
Sheet 2 of 2

STANDARD 701502

Illinois Department of Transportation

APPROVED: *[Signature]* DATE: _____

DESIGNED BY: *[Signature]*

APPROVED: *[Signature]* DATE: _____

PROJECT: *[Signature]*

STANDARD 701502

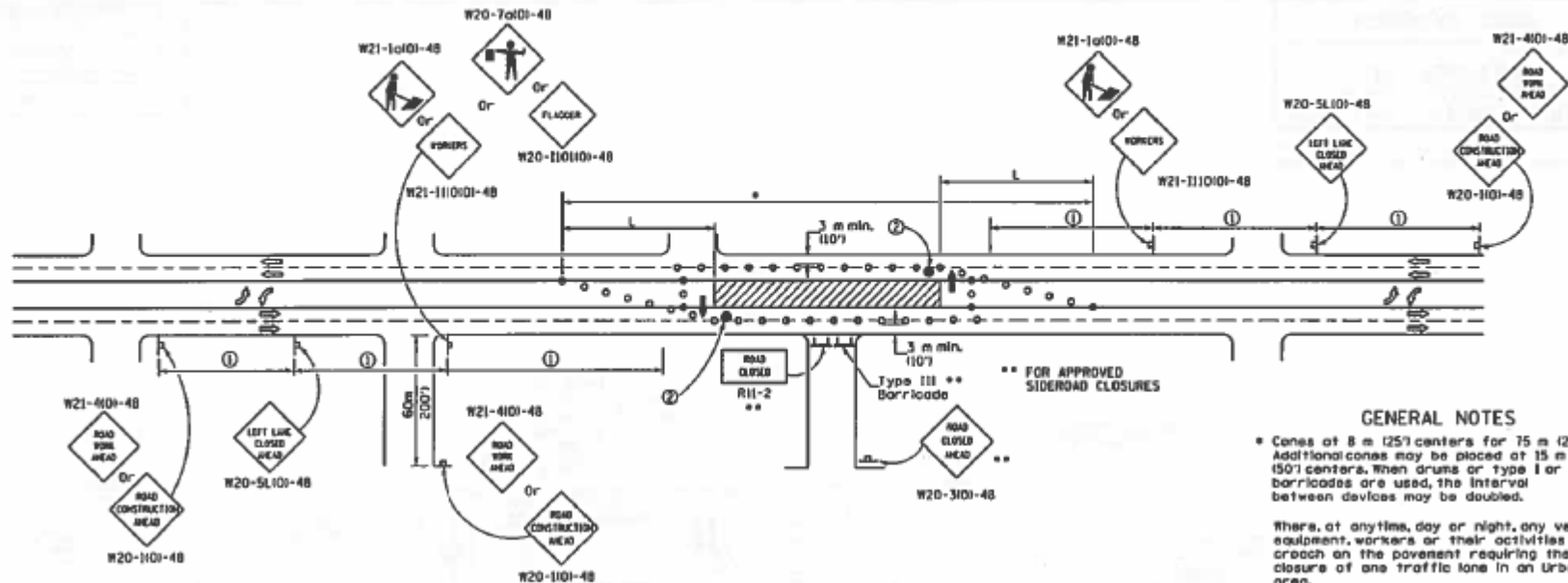

CASE I

GENERAL NOTES

* Cones at 8 m (25') centers for 75 m (250'). Additional cones may be placed at 15 m (50') centers. When drums or type I or II barricades are used, the interval between devices may be doubled.

Where, at anytime, day or night, any vehicle, equipment, workers or their activities encroach on the pavement requiring the closure of one traffic lane in an urban area.

Where L is:

SPEED LIMIT	FORMULAS	
70 km/h (40 mph) or less:	Metric	(English)
	$L = \frac{WS^2}{150}$	$L = \frac{WS^2}{50}$

80 km/h (45 mph) or greater: $L = 0.65(WHS)$ $L = (WHS)$

W = Width of offset in meters (feet).

S = Normal posted speed km/h (mph).

If the work operation is performed between 9:00 a.m. and 3:00 p.m. and does not exceed 15 min. Traffic protection shall be as shown for Standard 701426.

All dimensions are in millimeters (inches) unless otherwise shown.

SIGN SPACING	
Posted Speed	Sign Spacing
55 (4)	150 m (500')
50-45 (4)	118 m (350')
<45	60 m (200')

- ① Refer to SIGN SPACING TABLE for distances.
- ② Required for speeds > 70 km/h (40 mph).
- ③ Required if work exceeds 164 m (500') or 1 block.
- ④ For speeds exceeding 80 km/h (45 mph) contact the District Operations Office for approval of sign spacing.

SYMBOLS

- ↑ Arrow board
- ▨ Work area
- ⚡ Barricade or drum with steady burning nondirectional light
- [Barricade or drum without flashing light
- Flagger with traffic control sign
- Cone, drum or barricade (Cone for daytime use only)
- ⊥ Sign on portable or permanent support

State Department of Transportation

APPROVED: [Signature] 7001

DESIGNED BY: [Signature] 7001

APPROVED: [Signature] 7001

DATE: 10-1-01

DATE	REVISIONS
1-1-01	New Standard

URBAN LANE CLOSURE, MULTILANE, 2W WITH BIDIRECTIONAL LEFT TURN LANE

(Sheet 1 of 4)

STANDARD 701602

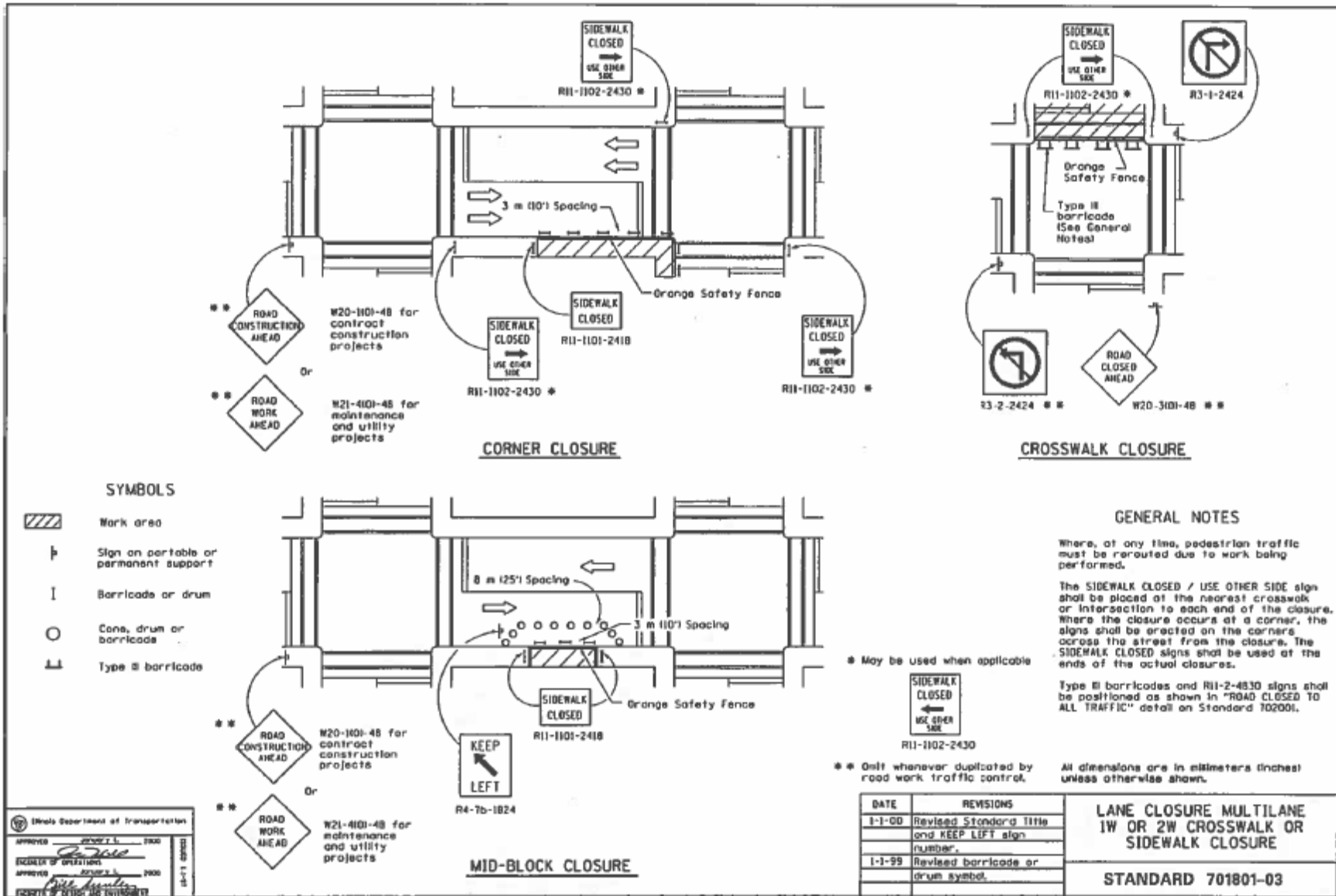

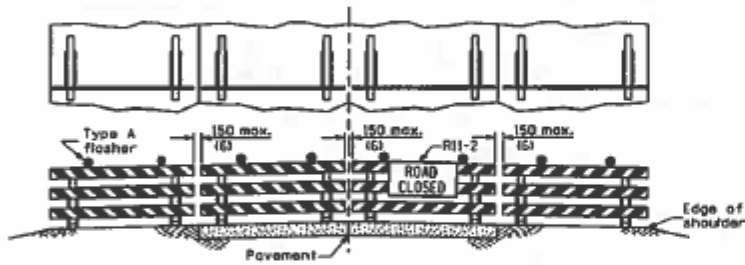

ROAD CLOSED TO ALL TRAFFIC
 ReflectORIZED striping may be omitted on the back side of the barricades. The barricades shall be to the edge of the shoulders except when otherwise directed by the Engineer or shown on the detailed construction plans.

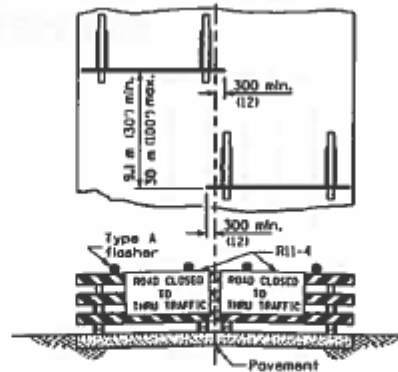

ROAD CLOSED TO ALL THRU TRAFFIC
 ReflectORIZED striping shall appear on both sides of the barricades. The barricades shall be to the edge of the pavement except when otherwise directed by the Engineer or shown on the detailed construction plans.

ROAD CONSTRUCTION NEXT X MILES
 G20-1101-6036

END CONSTRUCTION
 G20-2101-6024

This signing is required for all projects over 3200 m (2 miles) or more in length.
 ROAD CONSTRUCTION NEXT X MILES sign shall be placed 150 m (500') in advance of project limits.
 END CONSTRUCTION sign shall be erected at the of the job unless another job is within 3200 m (2 miles).

WORK LIMIT SIGNING

TYPICAL APPLICATIONS OF TYPE III BARRICADES CLOSING A ROAD

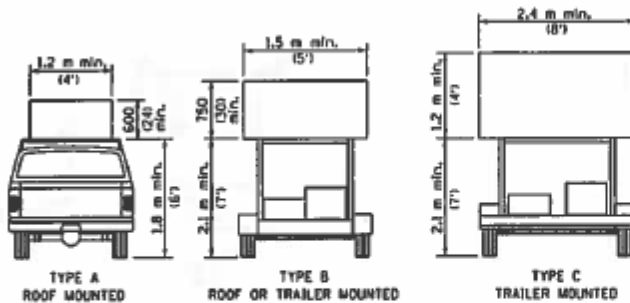

ARROW BOARDS

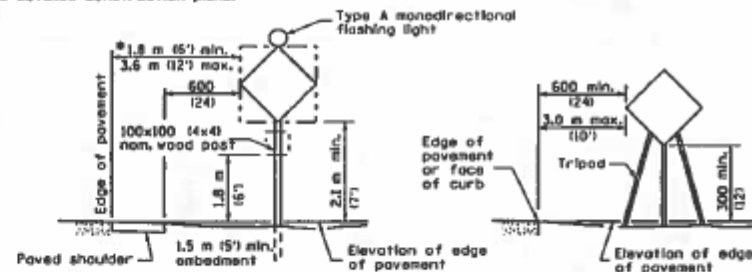

TYPICAL SIGN INSTALLATIONS

GENERAL NOTES

- When curb or paved shoulder are present this dimension shall be 600 mm (24") to the face of curb or 1.8 m (6') to the outside edge of the paved shoulder.
- All heights shown shall be measured above the pavement surface.
- All dimensions are in millimeters (inches) unless otherwise shown.

Missouri Department of Transportation
 APPROVED: [Signature] 1001
 CHECKED BY: [Signature] 1001
 APPROVED: [Signature] 1001
 PROJECT NO. 2001-100-1001

DATE	REVISIONS
1-1-01	Added the word limits in Work Limit Signing det.
	Removed tubular marker.
1-1-00	Rev. max. tripod sign offset & END CONST. sign number.

TRAFFIC CONTROL DEVICES

(Sheet 1 of 3)

STANDARD 702001-02

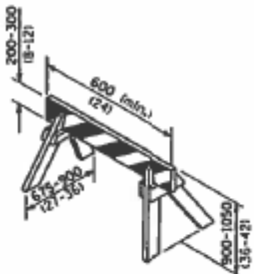

TYPE 1A BARRICADE

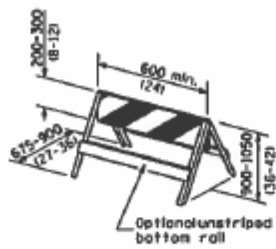

TYPE I BARRICADE

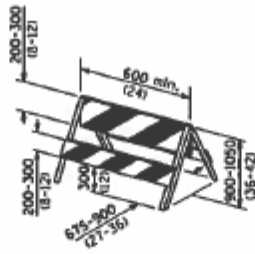

TYPE II BARRICADE

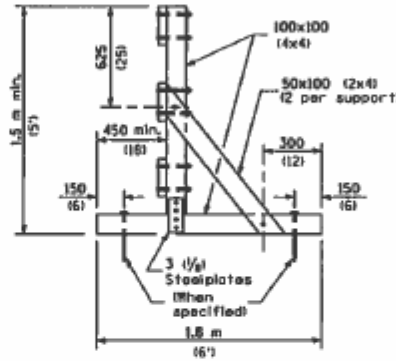
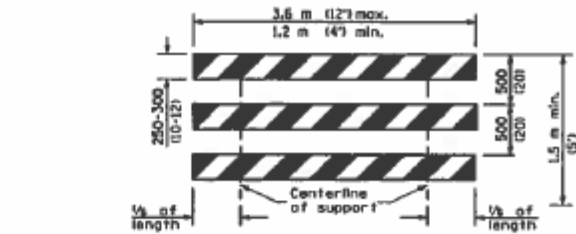

TYPICAL WOOD SUPPORT

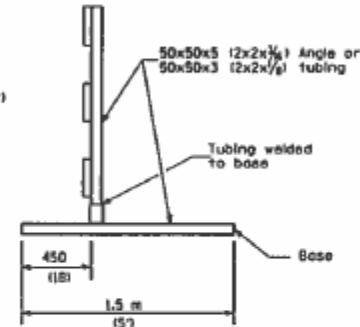

TYPICAL STEEL SUPPORT

TYPE III BARRICADES

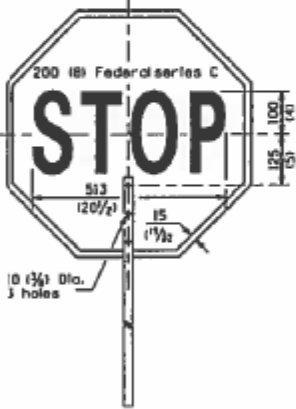

**FRONT SIDE
FLAGGER TRAFFIC CONTROL SIGN**

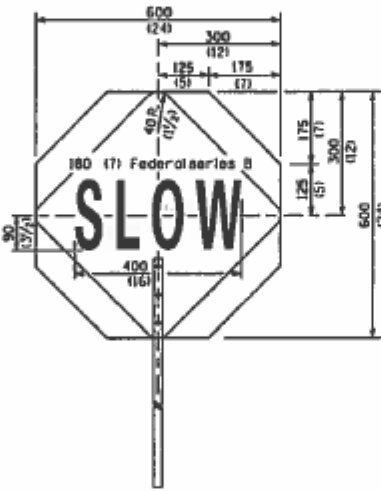

REVERSE SIDE

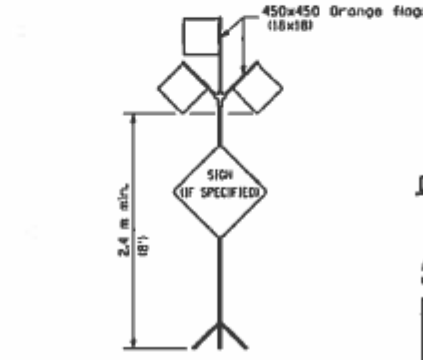

HIGH LEVEL WARNING DEVICE

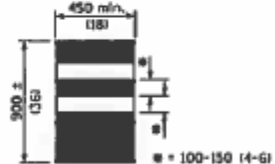

**DRUMS AND SAND MODULE
IMPACT ATTENUATORS**

All dimensions are in millimeters (inches) unless otherwise shown.

TRAFFIC CONTROL DEVICES
(Sheet 3 of 3)
STANDARD 702001-02

State Department of Transportation
APPROVED: [Signature] 200
DIRECTOR OF TRANSPORTATION
APPROVED: [Signature] 200
CHIEF OF STAFF FOR TRANSPORTATION
14-11 02002

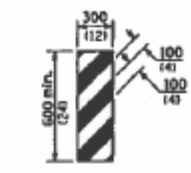

VERTICAL PANELS

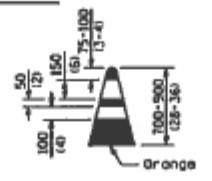

REFLECTORIZED CONES



CONES

IV
BID FORM (Pricing)

The undersigned bidder agrees to all terms and conditions of the preceding specifications for 2024 Water Service Line Replacement Program and will furnish all the insurance documents and security deposits as stipulated. The unit prices listed below should be for 2024 only. Bid bond amount should be 10% of the sum of Bidder's Estimate amount listed below.

VILLAGE OF OAK PARK					
2024 WATER SERVICE LINE REPLACEMENT PROGRAM					
PROJECT # 24-					
ITEM #	ITEM DESCRIPTION	QUANTITY	UNITS	UNIT PRICE	COST
1	TRENCH BACKFILL	750	CU.YD.		
2	PROJECT MANAGEMENT(PUBLIC SIDE)	40	HRS		
3	UTILITY LOCATION - PRIVATE PROPERTY	20	EACH		
4	UTILITY CONFLICT POTHOLE	5	EACH		
5	SERVICE CONNECTION TO WATER MAIN EXCAVATION	50	EACH		
6	PARKWAY EXCAVATION	20	EACH		
7	WATER SERVICE DISCONNECTION EXCAVATION	5	EACH		
8	WATER SERVICE CONNECTION-PRIVATE PROPERTY	20	EACH		
9	WATER SERVICE LINE, OPEN CUT, 1"	30	LIN.FT.		
10	WATER SERVICE LINE, OPEN CUT, 1-1/2"	30	LIN.FT.		
11	WATER SERVICE LINE, OPEN CUT, 2"	30	LIN.FT.		
12	WATER SERVICE LINE, DIRECTIONAL DRILL, 1"	2125	LIN.FT.		
13	WATER SERVICE LINE, DIRECTIONAL DRILL, 1-1/2"	450	LIN.FT.		
14	WATER SERVICE LINE, DIRECTIONAL DRILL, 2"	30	LIN.FT.		
15	WATER METER RELOCATION	2	EACH		
16	WATER SERVICE LINE TYPE L 3/4"	40	LIN.FT.		
17	WATER SERVICE LINE TYPE L 1"	40	LIN.FT.		
18	REMOVE AND REPLACE HOT WATER HEATER	1	EACH		
19	HAND DIG EXCAVATION ALLOWANCE, 5' DEEP	1	EACH		
20	HAND DIG EXCAVATION ALLOWANCE, 6' DEEP	1	EACH		
21	REMOVE AND REPLACE DRAIN TILES	5	LIN.FT.		
22	REMOVE AND REPLACE SEWER SERVICE LINES	25	LIN.FT.		
23	LANDSCAPE RESTORATION(PRIVATE PROPERTY)	100	SQ.FT		
24	REMOVAL AND DISPOSAL OF CONTAMINATED MATERIAL	7	CU.YD.		
BIDDER'S ESTIMATE:					

(Print Name of Individual Signing)

Signed

Illinois Plumbing License #: _____

being first duly sworn on oath deposes and says that the bidder on the above Bid is organized as indicated below and that all statements herein made on behalf of such bidder and that their deponent is authorized to make them, and also deposes and says that deponent has examined and carefully prepared their Bid from the Agreement Specifications and has checked the same in detail before submitting this Bid; that the statements contained herein are true and correct.

Signature of bidder authorizes the Village of Oak Park to verify references of business and credit at its option.

Signature of bidder shall also be acknowledged before a Notary Public or other person authorized by law to execute such acknowledgments.

Dated: _____/_____/2023

Organization Name (Seal - If Corporation)

By:

Authorized Signature

Address

Telephone

E-mail

Subscribed and sworn to before me this _____ day of _____, 2023.

Notary Public in the State of _____. My Commission

Expires on ____/____/_____

BID FORM CONTINUED

Complete Applicable Paragraph Below

(a) Corporation

The bidder is a corporation, which operates under the legal name of

_____ and is organized and existing under the laws of the State of _____ . The full names of its Officers are:

President _____

Secretary _____

Treasurer _____

The corporation does have a corporate seal. (In the event that this Bid is executed by a person other than the President, attach hereto a certified copy of that section of Corporate By-Laws or other authorization by the Corporation that permits the person to execute the offer for the corporation.)

(b) Partnership

Names, Signatures, and Addresses of all Partners

The partnership does business under the legal name of _____, which name is registered with the office of _____ in the county of _____ .

(c) Sole Proprietor

The bidder is a Sole Proprietor whose full name is _____ . If the

bidder is operating under a trade name,

said trade name is _____,

which name is registered with the office of _____

in the county of _____ .

Signed: _____

Sole Proprietor

In compliance with the above, the undersigned offers and agrees, if his/her Bid is accepted within ninety (90) calendar days from date of opening, to furnish any or all of the items upon which prices are quoted, at the price set opposite each item, delivered at the designated point within the time specified above.

MUNICIPAL QUALIFICATION REFERENCE SHEET

Bidders shall furnish a minimum of four (4) references from projects similar in scope within the last two (2) years.

MUNICIPALITY _____
ADDRESS _____

CONTACT _____
PHONE _____
WORK _____
PERFORMED _____

MUNICIPALITY _____
ADDRESS _____

CONTACT _____
PHONE _____
WORK _____
PERFORMED _____

MUNICIPALITY _____
ADDRESS _____

CONTACT _____
PHONE _____
WORK _____
PERFORMED _____

MUNICIPALITY _____
ADDRESS _____

CONTACT _____
PHONE _____
WORK _____
PERFORMED _____

V
BIDDER CERTIFICATION

_____, as part of its Bid on an agreement for 2024 Water service Line Replacement Program for the Village of Oak Park, hereby certifies that said bidder selected is not barred from proposing on the aforementioned agreement as a result of a violation to either Section 33E-3 or 33E-4 of Article 33E of Chapter 38 of the Illinois Revised Statutes or Section 2-6-12 of the Oak Park Village Code relating to "Proposing Requirement.

(Authorized Agent of bidder selected)

Subscribed and sworn to before me this _____ day of _____, 2023.

Notary Public's Signature

- Notary Public Seal -

VI
TAX COMPLIANCE AFFIDAVIT

_____, being first duly sworn, deposes and says:

that he/she is _____ of
(partner, officer, owner, etc.)

(bidder selected)

The individual or entity making the foregoing Bid or proposal certifies that he/she is not barred from entering into an agreement with the Village of Oak Park because of any delinquency in the payment of any tax administered by the Department of Revenue unless the individual or entity is contesting, in accordance with the procedures established by the appropriate revenue act, liability for the tax or the amount of the tax. The individual or entity making the Bid or proposal understands that making a false statement regarding delinquency in taxes is a Class A Misdemeanor and, in addition, voids the agreement and allows the municipality to recover all amounts paid to the individual or entity under the agreement in civil action.

By:
Its:

(name of bidder if the bidder is an individual)
(name of partner if the bidder is a partnership)
(name of officer if the bidder is a corporation)

The above statement must be subscribed and sworn to before a notary public.

Subscribed and sworn to before me this _____ day of _____, 2023.

Notary Public's Signature

- Notary Public Seal -

VII
ORGANIZATION OF BIDDING FIRM

Please fill out the applicable section:

A. Corporation:

The Contractor is a corporation, legally named _____ and is organized and existing in good standing under the laws of the State of _____. The full names of its Officers are:

President _____

Secretary _____

Treasurer _____

Registered Agent Name and Address: _____

The corporation has a corporate seal. (In the event that this Bid is executed by a person other than the President, attach hereto a certified copy of that section of Corporate By-Laws or other authorization by the Corporation that permits the person to execute the offer for the corporation.)

B. Sole Proprietor:

The Contractor is a Sole Proprietor. If the Contractor does business under an Assumed Name, the Assumed Name is _____, which is registered with the Cook County Clerk. The Contractor is otherwise in compliance with the Assumed Business Name Act, 805 ILCS 405/0.01, et. seq.

C. Partnership:

The Contractor is a Partnership which operates under the name _____

The following are the names, addresses and signatures of all partners:

Signature

Signature

(Attach additional sheets if necessary.) If so, check here _____.

If the partnership does business under an assumed name, the assumed name must be registered with the Cook County Clerk and the partnership is otherwise in compliance with the Assumed Business Name Act, 805 ILCS 405/0.01, et. seq.

D. Affiliates: The name and address of any affiliated entity of the business, including a description of the affiliation: _____

Signature of Owner

SECTION VIII
BID BOND

WE _____

as PRINCIPAL, and _____
as SURETY, are held and firmly bound unto the Village of Oak Park, Illinois (hereafter referred to as "VOP") in the penal sum of Ten Percent (10%) of the total bid price, as specified in the invitation for bids. We bind ourselves, our heirs, executors, administrators, successors, and assigns, jointly to pay to the VOP this sum under the conditions of this instrument.

WHEREAS THE CONDITION OF THE FOREGOING OBLIGATION IS SUCH that, the said PRINCIPAL is submitting a written bid to the VOP acting through its awarding authority for the completion of the work designated as the above section.

THEREFORE if the bid is accepted and an agreement awarded to the PRINCIPAL by the VOP for the above-designated section and the PRINCIPAL shall within fifteen (15) days after award enter into a formal agreement, furnish surety guaranteeing the faithful performance of the work, and furnish evidence of the required insurance coverage, all as provided in Specifications then this obligation shall become void; otherwise it shall remain in full force and effect.

IN THE EVENT the VOP determines the PRINCIPAL has failed to enter into a formal agreement in compliance with any requirements set forth in the preceding paragraph, then the VOP acting through its awarding authority shall immediately be entitled to recover the full penal sum set out above, together with all court costs, all attorney fees, and any other expense of recovery.

IN TESTIMONY WHEREOF, the said PRINCIPAL and the said SURETY have caused this instrument to be signed by their respective officers this _____ day of _____ A.D. 2023.

PRINCIPAL

(Company Name) (Company Name)

By: _____ By: _____
(Signature & Title) (Signature & Title)

(If PRINCIPAL is a joint venture of two or more Contractors, the company names, and authorized signatures of each Contractor must be affixed)

BID BOND CONTINUED

Subscribed to and Sworn before me on the

_____ day of _____, 2023.

Notary Public

NAME OF SURETY

By: _____
Signature of Attorney-in-Fact

Subscribed to and Sworn before me on the

_____ day of _____, 2023.

Notary Public

SECTION IX
COMPLIANCE AFFIDAVIT

I, _____, (Print Name) being first duly sworn on oath depose and state:

1. I am the (title) _____ of the Proposing Firm and am authorized to make the statements contained in this affidavit on behalf of the firm;
2. I have examined and carefully prepared this Bid based on the request and have verified the facts contained in the Bid in detail before submitting it;
3. The Proposing Firm is organized as indicated above on the form entitled "Organization of Proposing Firm."
4. I authorize the Village of Oak Park to verify the Firm's business references and credit at its option;
5. Neither the Proposing Firm nor its affiliates¹ are barred from proposing on this project as a result of a violation of 720 ILCS 5/33E-3 or 33E-4 relating to Bid rigging and Bid rotating, or Section 2-6-12 of the Oak Park Village Code relating to "Proposing Requirements".
6. The Proposing Firm has the M/W/DBE status indicated below on the form entitled "EEO Report."
7. Neither the Proposing Firm nor its affiliates is barred from agreementing with the Village of Oak Park because of any delinquency in the payment of any debt or tax owed to the Village except for those taxes which the Proposing Firm is contesting, in accordance with the procedures established by the appropriate revenue act, liability for the tax or the amount of the tax. I understand that making a false statement regarding delinquency in taxes is a Class A Misdemeanor and, in addition, voids the agreement and allows the Village of Oak Park to recover all amounts paid to the Proposing Firm under the agreement in civil action.
8. I am familiar with Section 13-3-2 through 13-3-4 of the Oak Park Village Code relating to Fair Employment Practices and understand the contents thereof; and state that the Proposing Firm is an "Equal Opportunity Employer" as defined by Section 2000(E) of Chapter 21, Title 42 of the United States Code Annotated and Federal Executive Orders #11246 and #11375 which are incorporated herein by reference. **Also complete the attached EEO Report or Submit an EEO-1.**
9. I certify that the Contractor is in compliance with the Drug Free Workplace Act, 41 U.S.C.A, 702

Signature: _____

Name and address of Business: _____

Telephone _____ E-Mail _____

Subscribed to and sworn before me this _____ day of _____, 2019.

Notary Public

- Notary Public Seal -

¹ Affiliates means: (i) any subsidiary or parent of the agreementing business entity, (ii) any member of the same unitary business group; (iii) any person with any ownership interest or distributive share of the agreementing business entity in excess of 7.5%; (iv) any entity owned or controlled by an executive employee, his or her spouse or minor children of the agreementing business entity.

SECTION X
M/W/DBE STATUS AND EEO REPORT

Failure to respond truthfully to any questions on this form, failure to complete the form or failure to cooperate fully with further inquiry by the Village of Oak Park will result in disqualification of this Bid. For assistance in completing this form, contact the Department of Public Works at 708-358-5700.

1. Contractor Name: _____

2. Check here if your firm is:

- Minority Business Enterprise (MBE) (A firm that is at least 51% owned, managed and controlled by a Minority.)
- Women's Business Enterprise (WBE) (A firm that is at least 51% owned, managed and controlled by a Woman.)
- Owned by a person with a disability (DBE) (A firm that is at least 51% owned by a person with a disability)
- None of the above

[Submit copies of any W/W/DBE certifications]

3. What is the size of the firm's current stable work force?

_____ Number of full-time employees

_____ Number of part-time employees

4. Similar information will be requested of all subcontractors working on this agreement. Forms will be furnished to the lowest responsible Contractor with the notice of agreement award, and these forms must be completed and submitted to the Village before the execution of the agreement by the Village.

Signature: _____

Date: _____

EEO REPORT

Please fill out this form completely. Failure to respond truthfully to any questions on this form, or failure to cooperate fully with further inquiry by the Village of Oak Park will result in disqualification of this Bid. An incomplete form will disqualify your Bid. For assistance in completing this form, contact the Purchasing Department at 708-358-5473.

An EEO-1 Report may be submitted in lieu of this report

Contractor Name _____

Total Employees _____

Job Categories	Total Employees	Total Males	Total Females	Males				Females				Total Minorities	
				Black	Hispanic	American Indian & Alaskan Native	Asian & Pacific Islander	Black	Hispanic	American Indian & Alaskan Native	Asian & Pacific Islander		
Officials & Managers													
Professionals													
Technicians													
Sales Workers													
Office & Clerical													
Semi-Skilled													
Laborers													
Service Workers													
TOTAL													
Management Trainees													
Apprentices													

This completed and notarized report must accompany your Bid. It should be attached to your Affidavit of Compliance. Failure to include it with your Bid will be disqualify you from consideration.

_____, being first duly sworn, deposes and says that he/she is the _____

(Name of Person Making Affidavit)

(Title or Officer)

of _____ and that the above EEO Report information is true and accurate and is submitted with the intent that it

be relied upon. Subscribed and sworn to before me this _____ day of _____, 20__.

(Signature)

(Date)

SECTION XI
NO BID EXPLANATION

If your firm does not wish to propose on the attached specifications, the Village of Oak Park would be interested in any explanation or comment you may have as to what prevented your firm from submitting a Bid.

Bid Name: **Project No. 24-102; Village of Oak Park 2024 Water Service Line Replacement Program**

Comments:

Signed: _____

Phone: _____

XII
CONTRACT BOND
(For Reference – Do Not Fill Out)

Contract Bond

_____, as PRINCIPAL, and
_____ as SURETY, are held and firmly bound unto the
Village of Oak Park (hereafter referred to as "Village") in the penal sum of
_____, well and truly to be paid to the
Village, for the payment of which its heirs, executors, administrators, successors and assigns,
are bound jointly to pay to the Village under the conditions of this instrument.

WHEREAS, THE CONDITION OF THE FOREGOING OBLIGATION IS SUCH that, the Principal has entered into a written contract with the Village, acting through its President and Board of Trustees, for the construction of work, which contract is hereby referred to and made a part hereof as if written herein at length, and whereby the Principal has promised and agreed to perform the work in accordance with the terms of the contract, and has promised to pay all sums of money due for any labor, materials, apparatus, fixtures or machinery furnished to such Principal for the purpose of performing such work, including paying not less than the prevailing rate of wages in Cook County, where the work is for the construction of any public work subject to the Prevailing Wage Act, and has further agreed to save and indemnify and keep harmless the Village against all liabilities, judgments, costs and expenses which may in any manner accrue against the Village in consequence of granting such contract or which may in any manner result from the carelessness or neglect of the Principal, his agents, employees or workmen in any respect whatever; and has further agreed that this bond will inure to the benefit of any person, firm, company, or corporation, to whom any money may be due from the Principal, subcontractor or otherwise, for any such labor, materials, apparatus, fixtures or machinery so furnished and that suit may be maintained on such bond by any such person, firm, company, or corporation, for the recovery of any such money.

NOW THEREFORE, if the Principal shall well and truly perform the work in accordance with the terms of the contract, and shall pay all sums of money due or to become due for any labor, materials, apparatus, fixtures or machinery furnished to it for the purpose of constructing such work, and shall commence and complete the work within the time prescribed in the contract, and shall pay and discharge all damages, direct and indirect, that may be suffered or sustained on account of such work during the time of performance thereof and until the work shall have been accepted, and shall save and indemnify and keep harmless the Village against all liabilities, judgments, costs and expenses which may in any manner accrue against the Village in consequence of granting such contract or which may in any manner result from the carelessness or neglect of the Principal, his agents, employees or workmen in any respect

CONTRACT BOND CONTINUED

whatever; and shall in all respects fully and faithfully comply with all the provisions, conditions, and requirements of the contract, then this obligation will be void; otherwise it will remain in full force and effect.

IN WITNESS WHEREOF, the PRINCIPAL and the SURETY have caused this instrument to be signed by their respective officers this ____ day of _____, 2023.

NAME OF PRINCIPAL

By: _____
Signature

By: _____
Printed Name

Its: _____
Title

Subscribed to and Sworn before me on the
____ day of _____, 2023.

Notary Public

NAME OF SURETY

By: _____
Signature of Attorney-in-Fact

Subscribed to and Sworn before me on the
____ day of _____, 2023.

Notary Public



SECTION XIII
(For Reference – Do Not Fill Out)
SAMPLE INDEPENDENT CONTRACTOR AGREEMENT

THIS INDEPENDENT CONTRACTOR AGREEMENT (hereinafter “Contract” or “Agreement”) is entered into on the ____ day of _____, 2023, by and between the Village of Oak Park, an Illinois home rule municipal corporation (hereinafter referred to as the “Village”), and _____, an _____ corporation/limited liability company authorized to conduct business in the State of Illinois (hereinafter referred to as the “Contractor”).

WHEREAS, Contractor submitted a bid dated _____, _____, a copy of which is attached hereto and incorporated herein by reference, to provide Water Service Line Replacement Program (hereinafter referred to as the “Work”) for **Project 24-xxx Water Service Line Replacement Program** (hereinafter referred to as the “Project”) pursuant to the Village’s Request for Bids dated **October 5, 2023** incorporated herein by reference as though fully set forth; and

WHEREAS, the Contractor represented in said Bid that it has the necessary personnel, experience, and competence to promptly complete the Project and the work required hereunder (hereinafter referred to as the “Work”); and

WHEREAS, Contractor shall perform the Work pursuant to the terms and conditions of this Contract.

NOW, THEREFORE, in consideration of the premises and the mutual promises contained in this Contract, and other good and valuable consideration received and to be received, it is mutually agreed by and between the parties as follows:

1. RECITALS INCORPORATED

The above recitals are incorporated herein as though fully set forth.

2. SCOPE OF WORK

The Contractor shall perform the Project in accordance with its Bid in an amount not to exceed \$_____ (“Contract Price”). The Contractor shall complete the Project in accordance with any applicable manufacturers’ warranties and in accordance with the Village’s Request for Bids, the Contractor’s Bid and this Contract, all of which together shall constitute the “Contract Documents.” The Contractor hereby represents and

warrants that it has the skill and experience necessary to complete this project in a good and workmanlike manner. The Contractor further represents and warrants that the Project will be completed in a good and workmanlike manner in accordance with the Contract Documents, and that the Project will be free from defects.

The Contractor shall achieve completion of all work required pursuant to the Contract Documents by _____, 2023 ("Contract Time"). The Contract Time is of the essence. In the event the Contractor fails to complete the Project on or before said date, the Village shall be entitled to liquidated damages in the amount of \$500.00 per day for each day the work remains uncompleted beyond the completion date set forth above. This amount is not a penalty, and the parties agree to said amount given the difficulties associated with determining or calculating damages to the Village in the event the Project is not completed on time. The Contractor shall have no claim for damages, for compensation in excess of the Contract Price, or for a delay or extension of the Contract Time based upon conditions found at, or in the vicinity of, the site(s).

3. DESIGNATED REPRESENTATIVES

Contractor shall designate in writing a person to act as its designated representative with respect to the Work to be performed under this Contract who shall have the power and authority to make or grant or do all things, certificates, requests, demands, approvals, consents, notices and other actions required that are ministerial in nature or described in this Agreement for and on behalf of Contractor and with the effect of binding Contractor. The Village is entitled to rely on the full power and authority of the person executing this Contract on behalf of Contractor as having been properly and legally given by Contractor. Contractor shall have the right to change its designated representative by providing the Village with written notice of such change which notice shall be sent in accordance with Section 1 of this Agreement.

The Village's Public Works Director shall be deemed the Village's authorized representative for purposes of this Agreement, unless applicable law requires action by the Corporate Authorities, and shall have the power and authority to make or grant or do those things, certificates, requests, demands, approvals, consents, notices and other actions required that are ministerial in nature or described in this Agreement for and on behalf of the Village and with the effect of binding the Village as limited by this Contract. Contractor is entitled to rely on the full power and authority of the person executing this Agreement on behalf of the Village as having been properly and legally given by the Village. The Village shall have the right to change its authorized representative by providing Contractor with written notice of such change which notice shall be sent in accordance with Section 12 of this Agreement.

4. TERM OF CONTRACT

Contractor shall perform the Work pursuant to this Contract beginning on the effective date as defined herein and ending on the date that the Work is completed as determined by the Village. The Contractor shall invoice the Village for the Work provided pursuant to this Contract at the rates set forth in its Bid. The term of this Contract may be extended in writing for additional periods of time pursuant to the consent of the parties.

5. PAYMENT SCHEDULE

The Contractor shall, as a condition precedent to its right to receive any payment, submit to the Village an application for payment and such receipts, vouchers, and other documents as may be necessary to establish the Contractor's payment for all labor and material and the absence of any interest whether in the nature of a lien or otherwise of any party in any property, work, or fund with respect to the Work performed hereunder. Such documents shall include, where relevant, the following forms, copies of which are attached hereto:

- (i) Contractor's sworn statement;
- (ii) Contractor's partial or final waiver of lien;
- (iii) Subcontractor's sworn statement(s); and
- (iv) Subcontractor's partial or final waiver of lien.

Payment by the Village shall be conditioned upon an inspection by the Village of the work completed and submission of required waivers by the Contractor. Payment by the Village shall in no way constitute a waiver of, or relieve the Contractor from, any defects in the work. All payments shall be made in accordance with the Illinois Local Government Prompt Payment Act, 50 ILCS 505/1 *et seq.* Final payment for any Work performed by the Contractor pursuant to an invoice by the Contractor shall be made by the Village to the Contractor when the Contractor has fully performed the work and the work has been approved by the Village and submission of required waivers and paperwork by Contractor. Approval of the work and issuance of the final payment by the Village shall not constitute a waiver of, or release the Contractor from, any defects in the work.

The Village shall have the right to withhold from any payment due hereunder such amount as may reasonably appear necessary to compensate the Village for any actual or prospective loss due to Work which is defective or does not conform to the Contract Documents; damage for which the Contractor is liable hereunder; liens or claims of liens; claims of third parties, subcontractors, or material men; or any failure of the Contractor to perform any of its obligations under this Contract. The Village may apply any money withheld or due Contractor hereunder to reimburse itself for any and all costs, expenses, losses, damages, liabilities, suits, judgments, awards, and attorney's fees incurred, suffered, or sustained by the Village and chargeable to the Contractor.

6. TERMINATION

The Village may terminate this Contract for cause, which includes but is not necessarily limited to, the Contractor's failure to perform the work pursuant to this Contract. The Village shall provide the Contractor with five (5) days' written notice of a termination for cause pursuant to the provisions of Section 12 below. The Village may also terminate this Contract when it determines the same to be in its best interests by giving fourteen (14) days' written notice to the Contractor pursuant to the provisions of Section 12 below. In such event, the Village shall pay to the Contractor all amounts due for the work performed up to the date of termination.

7. COMPLIANCE WITH APPLICABLE LAWS

The Contractor shall comply with all applicable laws, regulations, and rules promulgated by any federal, state, county, municipal and/or other governmental unit or regulatory body now in effect during the performance of the work. By way of example only and not as a limitation, the following are included within the scope of the laws, regulations and rules with which the Contractor must comply: all forms of Workers Compensation Laws, all terms of the equal employment opportunity rules and regulations of the Illinois Department of Human Rights, statutes relating to contracts let by units of government, and all applicable civil rights and anti-discrimination laws and regulations.

8. INDEMNIFICATION

To the fullest extent permitted by law, the Contractor shall waive any right of contribution against the Village and shall indemnify and hold harmless the Village and its officers, officials, employees, volunteers and agents from and against all claims, damages, losses and expenses, including, but not limited to, legal fees (attorney's and paralegal's fees, expert fees and court costs) arising out of or resulting from the performance of the Contractor's work, provided that any such claim, damage, loss or expense is attributable to bodily injury, sickness, disease or death, or injury to or destruction of property, other than the work itself, including the loss of use resulting therefrom, or is attributable to misuse or improper use of trademark or copyright-protected material or otherwise protected intellectual property, to the extent it is caused in whole or in part by any wrongful or negligent act or omission of the Contractor, any subcontractor, anyone directly or indirectly employed by any of them or anyone for whose acts any of them may be liable. Such obligation shall not be construed to negate, abridge or otherwise reduce any other right to indemnity which the Village and its officers, officials, employees, volunteers and agents would otherwise have. The Contractor shall similarly protect, indemnify and hold and save harmless, the Village and its officers, officials, employees, volunteers and agents against and from any and all claims, costs, causes, actions and expenses, including, but not limited to, legal fees incurred by reason of the Contractor's breach of any of its obligations under, or the Contractor's default of, any provisions of this Contract. The indemnification obligations under this Section shall not be limited in any

way by any limitation on the amount or type of damages, compensation, or benefits payable by or for the Contractor or any subcontractor under workers' compensation or disability benefit acts or employee benefit acts.

9. **INSURANCE**

The Contractor shall, at the Contractor's expense, secure and maintain in effect throughout the duration of this Contract, insurance of the following kinds and limits set forth in this Section. The Contractor shall furnish "Certificates of Insurance" to the Village before beginning work on the Project pursuant to this Contract. All insurance policies shall be written with insurance companies licensed to do business in the State of Illinois and having a rating of at least A according to the latest edition of the Best's Key Rating Guide; and shall include a provision preventing cancellation of the insurance policy unless thirty (30) days prior written notice is given to the Village. This provision shall also be stated on each Certificate of Insurance: "Should any of the above described policies be canceled before the expiration date, the issuing company shall mail thirty (30) days written notice to the certificate holder named to the left."

The limits of liability for the insurance required shall provide coverage for not less than the following amounts, or greater where required by law:

(A) **Commercial General Liability:**

- i. Coverage to include Broad Form Property Damage, Contractual and Personal Injury.
- ii. Limits:

General Aggregate	\$ 2,000,000.00
Each Occurrence	\$ 1,000,000.00
Personal Injury	\$ 1,000,000.00
- iii. Coverage for all claims arising out of the Contractor's operations or premises and anyone directly or indirectly employed by the Contractor.

(B) **Workers' Compensation:**

- i. Workers' compensation insurance shall be provided in accordance with the provisions of the laws of the State of Illinois, including occupational disease provisions, for all employees who perform the Work pursuant to this Contract, and if work is subcontracted pursuant to the provisions of this Contract, the Contractor shall require each subcontractor similarly to provide worker's compensation insurance. In case employees engaged in hazardous work under this Contract are not protected under the Worker's Compensation Act, the Contractor shall provide, and shall cause each subcontractor to provide, adequate and suitable insurance for the protection of employees not otherwise provided.

(C) **Comprehensive Automobile Liability:**

i. Comprehensive Automobile Liability coverage shall include all owned, hired, non-owned vehicles, and/or trailers and other equipment required to be licensed, covering personal injury, bodily injury and property damage.

ii. Limits:
Combined Single Limit \$1,000,000.00

(D) **Umbrella:**

i. Limits:
Each Occurrence/Aggregate \$2,000,000.00

(E) The Village and its officers, officials, employees, agents and volunteers shall be named as additional insureds on all insurance policies set forth herein except workers' compensation. The Contractor shall be responsible for the payment of any deductibles for said insurance policies. The coverage shall contain no special limitations on the scope of protection afforded to the Village and its officers, employees, agents, and volunteers.

(F) The Contractor understands and agrees that any insurance protection required by this Contract or otherwise provided by the Contractor, shall in no way limit the responsibility to indemnify, keep and save harmless, and defend the Village, its officers, officials, employees, agents and volunteers as herein provided. The Contractor waives and shall have its insurers waive, its rights of subrogation against the Village, its officers, officials, employees, agents and volunteers.

10. GUARANTY

The Contractor warrants and guarantees that its Work provided for the Project to be performed under this Contract, and all workmanship, materials, equipment, and supplies performed, furnished, used, or installed under this Contract, performed, furnished, used, or installed under this Contract, shall be free from defects and flaws in workmanship or design; shall strictly conform to the requirements of this Contract; and shall be fit and sufficient for the purposes expressed in, or reasonably inferred from, this Contract. The Contractor further warrants and guarantees that the strength of all parts of all manufactured materials, equipment, and supplies shall be adequate and as specified and that the performance requirements of this Contract shall be fulfilled.

The Contractor shall, at no expense to the Village, correct any failure to fulfill the above guaranty that may appear at any time. In any event, the guaranty herein expressed shall not be sole and exclusive, and is additional to any other guaranty or warranty expressed or implied.

11. AFFIDAVIT OR CERTIFICATE

The Contractor shall furnish any affidavit or certificate in connection with the work covered by this Contract as required by law.

12. NOTICES

Any notice required to be given by this Contract shall be deemed sufficient if made in writing and sent by certified mail, return receipt requested, by personal service, or by email transmission to the persons and addresses indicated below or to such addresses and persons as either party hereto shall notify the other party of in writing pursuant to the provisions of this Section:

To the Village:

Village Manager
Village of Oak Park
123 Madison
Oak Park, Illinois 60302
Email: VillageManager@oak-park.us

To Contractor:

Email:

Mailing of such notice as and when above provided shall be equivalent to personal notice and shall be deemed to have been given at the time of mailing.

Notice by email transmission shall be effective as of date and time of transmission, provided that the notice transmitted shall be sent on business days during business hours (9:00 a.m. to 5:00 p.m. Chicago time). In the event email notice is transmitted during non-business hours, the effective date and time of notice is the first hour of the first business day after transmission.

13. AUTHORITY TO EXECUTE

The individuals executing this Contract on behalf of the Contractor and the Village represent that they have the legal power, right, and actual authority to bind their respective parties to the terms and conditions of this Contract.

14. EFFECTIVE DATE

The effective date of this Contract as reflected above and below shall be the date that the Village Manager executes this Contract on behalf of the Village.

15. ENTIRE CONTRACT; APPROVAL OF SUBCONTRACTORS

This Contract, including the documents incorporated by reference herein, sets forth the entire Contract of the parties with respect to the accomplishment of the Work. No right or interest in this Contract shall be assigned, in whole or in part, by either party without the prior written consent of the other party. The Village reserves the right to approve or deny the use of subcontractors to complete any portion of the Work and to approve or deny any applicable contract between the Contractor and a proposed subcontractor to perform any of the Work. This Contract shall be binding upon the parties and upon their respective heirs, executors, administrators, personal representatives, successors, and assigns, except as herein provided.

16. INDEPENDENT CONTRACTOR

The Contractor shall have the full control of the ways and means of performing the work referred to above and that the Contractor and its employees, representatives or subcontractors are not employees of the Village, it being specifically agreed that the Contractor bears the relationship of an independent contractor to the Village. The Contractor shall solely be responsible for the payment of all salaries, benefits and costs of supplying personnel for the Work.

17. CONTRACT BOND

Before commencing the work on the Project, Contractor shall furnish a Contract Bond. The Contract Bond shall be in an amount equal to XX Thousand Dollars (\$XX,000.00) as security for the faithful performance of its obligations pursuant to the Contract Documents and as security for the payment of all persons performing labor and furnishing materials in connection with the Contract Documents. Such bond shall be on a standard AIA document, shall be issued by a surety satisfactory to the Village, and shall name the Village as a primary co-obligee. The Contract Bond shall become a part of the Contract Documents. The failure of Contractor to supply the required Contract Bond within ten (10) days after the Notice of Award or within such extended period as the Village may grant if the Contract Bond does not meet its approval shall constitute a default, and the Village may either award the Contract to the next lowest responsible proposer or re-advertise for Bids. A charge against Contractor may be made for the difference between the amount of Contractor's Bid and the amount for which a contract for the Work is subsequently executed, irrespective of whether the amount thus due exceeds the amount of the bid guarantee.

18. AMENDMENTS AND MODIFICATIONS

This Contract may be modified or amended from time-to-time provided, however, that no such amendment or modification shall be effective unless reduced to writing and duly

authorized and signed by the authorized representative of the Village and the authorized representative of the Contractor.

19. GOVERNING LAW AND VENUE

This Contract shall be governed by the laws of the State of Illinois both as to interpretation and performance. Venue for any action pursuant to this Contract shall be in the Circuit Court of Cook County, Illinois.

20. AMENDMENTS AND MODIFICATIONS

This Contract may be modified or amended from time-to-time provided, however, that no such amendment or modification shall be effective unless reduced to writing and duly authorized and signed by the authorized representative of the Village and the authorized representative of the Contractor.

21. NON-WAIVER OF RIGHTS

No failure of either party to exercise any power given to it hereunder or to insist upon strict compliance by the other party with its obligations hereunder, and no custom or practice of the parties at variance with the terms hereof, nor any payment under this Contract shall constitute a waiver of either party's right to demand exact compliance with the terms hereof.

22. CONFLICT

In case of a conflict between any provision(s) of the Village's Request for Bids or the Contractor's Bid and this Contract, this Contract and the Village's Request for Bids shall control to the extent of such conflict.

23. HEADINGS AND TITLES

The headings and titles provided in this Contract are for convenience only and shall not be deemed a part of this Contract.

24. COOPERATION OF THE PARTIES

The Village and the Contractor shall cooperate in the provision of the Work to be provided by Contractor pursuant to this Contract and in compliance with applicable laws, including, but not limited to, the Illinois Freedom of Information Act, 5 ILCS 140/1 *et seq.* ("FOIA"), and the provision of any documents and information pursuant to a FOIA request. The Contractor shall provide any and all responsive documents to the Village pursuant to a FOIA request at no cost to the Village.

25. COUNTERPARTS; FACSIMILE OR PDF SIGNATURES

This Contract may be executed in counterparts, each of which shall be considered an original and together shall be one and the same Contract. A facsimile or pdf/email copy of this Contract and any signatures thereon will be considered for all purposes as an original.

26. PREVAILING WAGES

Contractor and any applicable subcontractor shall pay prevailing wages as established by the Illinois Department of Labor and determined by the Village for each craft or type of work needed to execute the contract in accordance with the Illinois Prevailing Wage Act, 820 ILCS 130/0.01 *et seq.* ("Act") as applicable. Contractor shall prominently post the current schedule of prevailing wages at the Project site(s) and shall notify immediately in writing all of its subcontractors of all changes in the schedule of prevailing wages. Any increases in costs to Contractor due to changes in the prevailing rate of wage during the terms of any Contract shall be at the sole expense of Contractor and not at the expense of the Village, and shall not result in an increase to the Contract Price. Contractor shall be solely responsible to maintain accurate records as required by the Act and shall submit certified payroll records to the Village evidencing its compliance with the Act on no less than a monthly basis as required by the Act. Contractor shall be solely liable for paying the difference between prevailing wages and any wages actually received by laborers, workmen and/or mechanics engaged in the Work for the Project.

Contractor shall indemnify, hold harmless, and defend the Village, its officers, officials, employees, agents and volunteers ("Indemnified Parties") against all regulatory actions, complaints, damages, claims, suits, liabilities, liens, judgments, costs and expenses, including reasonable attorney's fees, which may in any way arise from or accrue against the Indemnified Parties as a consequence of noncompliance with the Act or which may in any way result therefrom, including a complaint by the Illinois Department of Labor under Section 4(a-3) of the Act, 820 ILCS 130/4(a-3) that any or all of the Indemnified Parties violated the Act by failing to give proper notice to the Grantee or any other party performing work on the Public Improvements that not less than the prevailing rate of wages shall be paid to all laborers, workers and mechanics performing Work on the Project, including interest, penalties or fines under Section 4(a-3). The indemnification obligations of this section on the part of Contractor shall survive the termination or expiration of this Agreement. In any such claim, complaint or action against the Indemnified Parties, Contractor shall, at its own expense, appear, defend and pay all charges of reasonable attorney's fees and all reasonable costs and other reasonable expenses arising therefrom or incurred in connection therewith, and, if any judgment or award shall be rendered against the Indemnified Parties in any such action, Contractor shall at its own expense, satisfy and discharge such judgment or award.

27. CERTIFIED PAYROLL

Contractor shall be solely responsible to maintain accurate records reflecting its payroll for its employees who perform any of the Work for the Village pursuant to this Contract and shall submit certified payroll records to the Village's Director of Public Works at any time during the term of this Contract. Contractor shall provide said certified payroll records within seven (7) days upon the request of the Director of Public Works.

28. EQUAL OPPORTUNITY EMPLOYER

Contractor is an equal opportunity employer and the requirements of 44 Ill. Adm. Code 750 APPENDIX A and Chapter 13 ("Human Rights") of the Oak Park Village Code are incorporated herein by reference.

The Contractor shall not discriminate against any employee or applicant for employment because of race, sex, gender identity, gender expression, color, religion, ancestry, national origin, veteran status, sexual orientation, age, marital status, familial status, source of income, disability, housing status, military discharge status, or order of protection status or physical or mental disabilities that do not impair ability to work, and further that it will examine all job classifications to determine if minority persons or women are underutilized and will take appropriate affirmative action to rectify any such underutilization. The Contractor shall comply with all requirements of Chapter 13 ("Human Rights") of the Oak Park Village Code.

In the event of the Contractor's noncompliance with any provision of Chapter 13 ("Human Rights") of the Oak Park Village Code, the Illinois Human Rights Act or any other applicable law, the Contractor may be declared non-responsible and therefore ineligible for future Agreements or subcontracts with the Village, and the Agreement may be cancelled or voided in whole or in part, and such other sanctions or penalties may be imposed or remedies invoked as provided by statute or regulation.

In all solicitations or advertisements for employees placed by it on its behalf, the Contractor shall state that all applicants will be afforded equal opportunity without discrimination because of race, sex, gender identity, gender expression, color, religion, ancestry, national origin, veteran status, sexual orientation, age, marital status, familial status, source of income, disability, housing status, military discharge status, or order of protection status or physical or mental disabilities that do not impair ability to work.

**[REMAINDER OF PAGE INTENTIONALLY LEFT BLANK –
SIGNATURE PAGE FOLLOWS]**

IN WITNESS WHEREOF, the parties hereto have caused this Contract to be signed by their duly authorized representatives on the days and dates set forth below.

VILLAGE OF OAK PARK

[full name of Contractor - capitalized]

By:
Its: Village Manager

By:
Its:

Date: _____, 2023

Date: _____, 2023

ATTEST

By:
Its:

Date: _____, 2023